

15 Assembly Drawing

This is one example of the Assembly Drawing of a Hisaka Plate Heat Exchanger. The following information is described in the Assembly Drawing.

- Tightening length for the heat transfer plates and full length of the PHE are illustrated.

- The PHE's external dimensions and connect position of piping are illustrated.

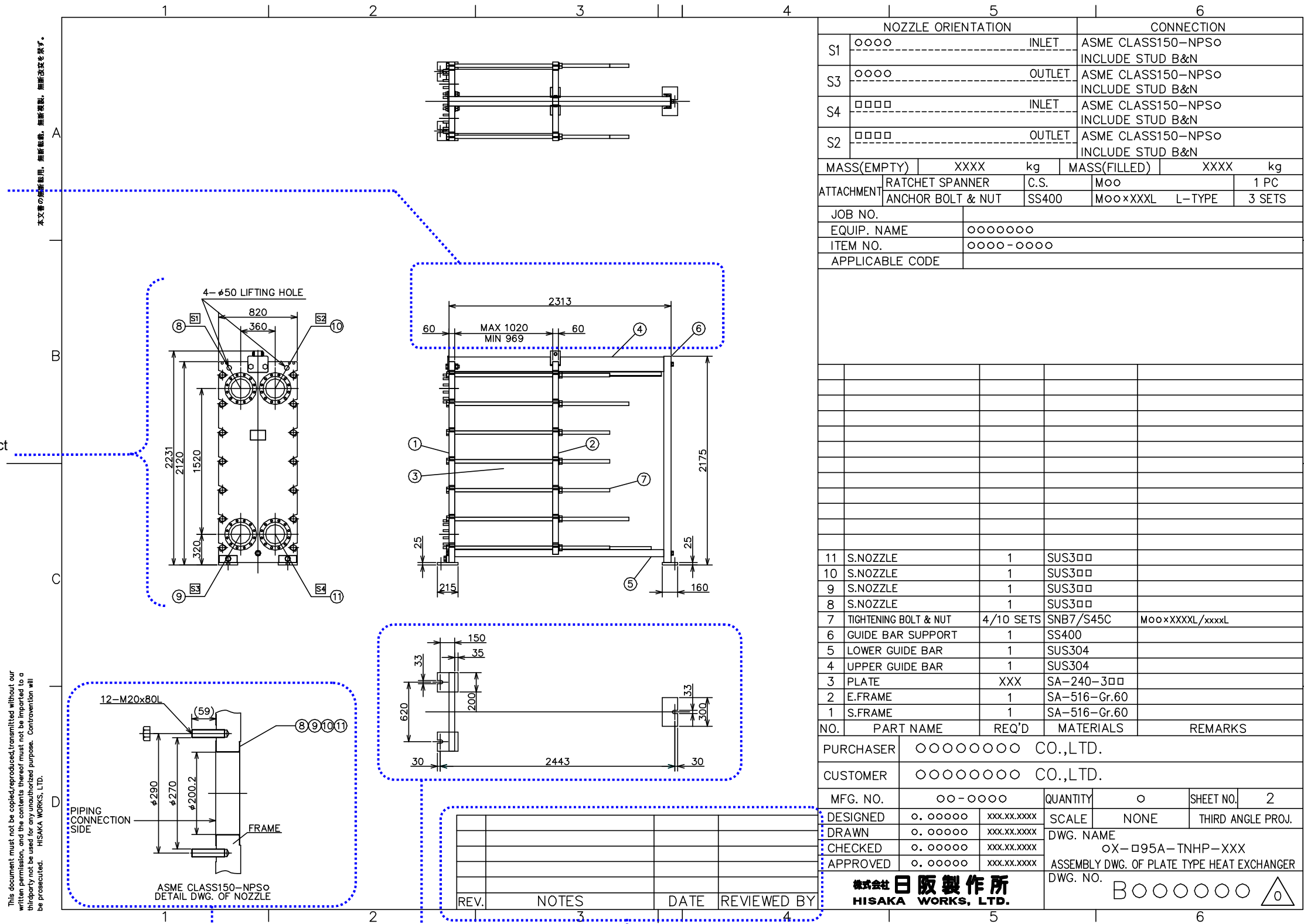

本文書の印刷・複製・転載、無断禁ず。無断複製、無断改定を禁ず。

This document must not be copied, reproduced, transmitted without our written permission, and the contents thereof must not be imparted to a third party not be used for any unauthorized purpose. Contention will be prosecuted. HISAKA WORKS, LTD.

- Some also include a detailed drawing of the nozzle.

- This is the a drawing of the equipment's foundation dimensions.

- Describes this drawing's revision history.

- Describes the position, standard, and diameter for piping to be mounted.

- Describes this equipment's weight.

- Describes accessories.

- Describes the equipment number, applicable regulations, and the like.

- Describes the names, materials, required quantity, and specifications of components in simple terms.

- Describes customer information.

- Describes the serial number, model, and number of equipment units.