

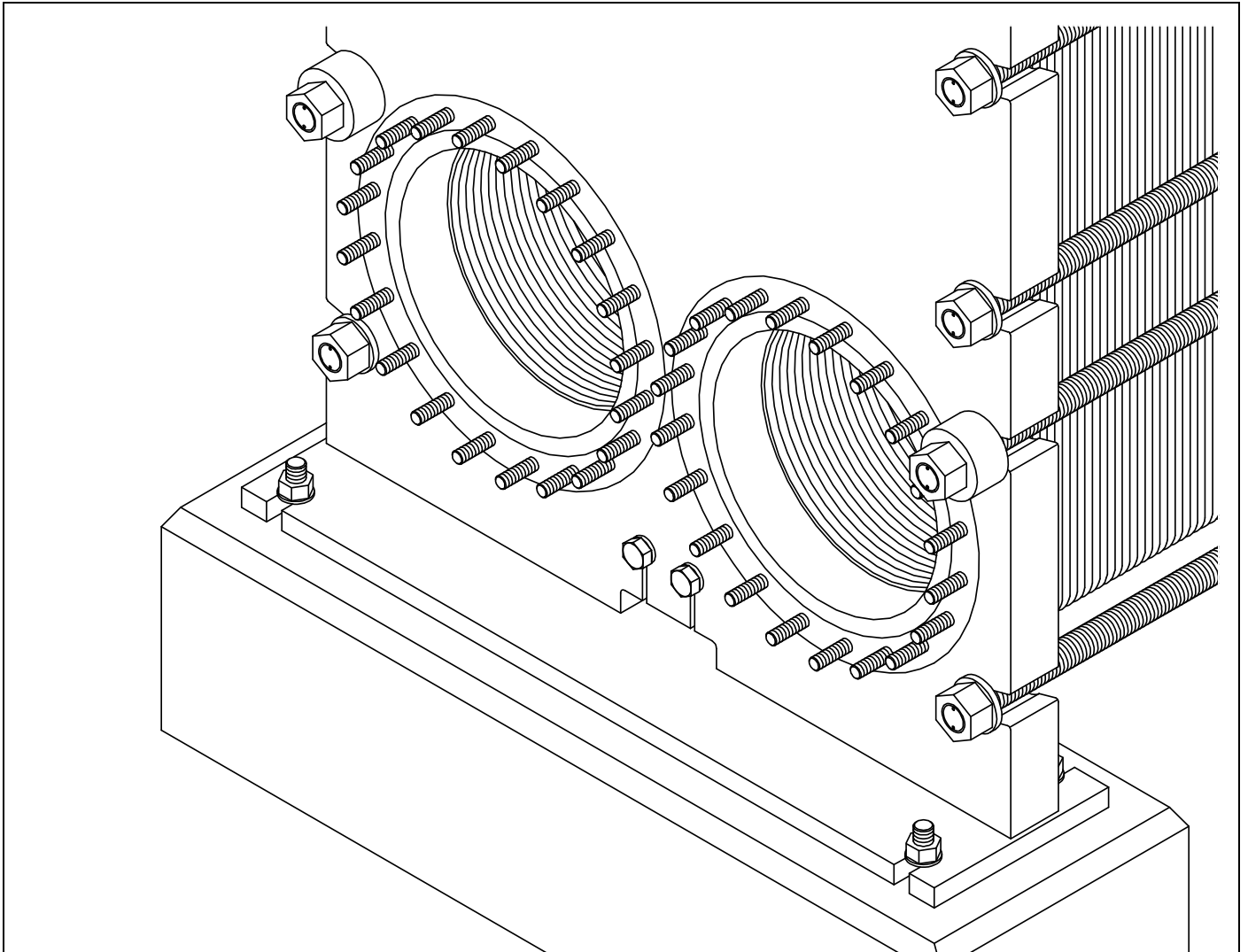

HISAKA

Plate Heat Exchanger

1 Installation Manual



Thank you for purchasing a Hisaka Plate Heat Exchanger.

- Manuals for the HISAKA Plate Heat Exchanger consist of the following seven related documents.
- 1. Installation Manual, 2. Operation and Maintenance Manual, 3. Gasketing Manual, 4. Plate Cleaning Manual, 5. "Slit-In" Type Gasketing Manual, 6. Mixed Gasket Materials Manual, and 7. Strainer Maintenance Manual.
These documents are available at our website (<https://www.hisaka.co.jp/english/>).
- Drawings (Plate Arrangement Drawing and Assembly Drawing) of supplied model are to be supplied with the equipment.
- Use as directed in these Manuals for safe and proper operation and maintenance.
- Keep these Manuals in hand.
- All description details, including appearance and specifications, presented in this manual are subject to change for improvement without prior notice. For the latest information, please refer to our website, if necessary.

Introduction

<Plate Heat Exchanger>

- Plate Heat Exchanger (hereinafter "PHE") performs heat exchanging by transferring heat between hot and cold fluids flowing alternately through heat transfer plates, which are thin metal sheets having fine corrugated patterns.

<Use of Equipment>

- To prevent injury to persons, do not use the equipment for anything other than its intended purpose and specification. Also, installation and maintenance shall be carried out according to these Manuals.

<Trained Operators>

- Operation, maintenance/inspection, or installation of the equipment shall be performed by personnel/operators who have undergone training regarding safety and danger prevention drills.
- Work in high places shall be performed by personnel/operators who have undergone training regarding safety and danger prevention drills.

<Export Regulations on the Equipment>

- According to the Export Control released by Japanese Government (METI), export of the equipment may be subject to export regulation under the Foreign Exchange and Foreign Trade Act. In case of exporting the equipment or component parts of equipment from Japan, reselling, relocating or re-exporting from an original installation site out of Japan, please comply with the relevant local regulations.

<Disposal of the Equipment>

- At the end of use, the equipment shall be disposed or recycled according to relevant, local regulations. Besides the equipment itself, any hazardous residues from the process liquid must be considered and dealt with in a proper manner.

<Use of this Installation Manual>

- Read this manual thoroughly and understand the precautions regarding the safety of the equipment and its functions before handling the equipment.
- This manual is created for a person who fully understands the language it is written in. If a person, who is not able to understand the language written herein, will handle the equipment, please provide safety instructions to the personnel/operators.
- PHE supplied may differ from the drawings and pictures in these Manuals depending on the optional parts if any. Also, for the purpose of explanation, the drawings and pictures in these Manuals may omit the details, accessories, or the like.
- Changing the contents of these Manuals, in part or in whole, or using them for anything other than its intended purpose is prohibited.

<Disclaimer>

- HISAKA accepts no liability for any failures in the function or performance of the equipment caused by use of any other than genuine parts.
- HISAKA accepts no liability for any injuries or damage borne by the user, caused by use of any other than genuine parts.
- Warranty condition for products are based on document specifying valid condition such as the sales contract before ordering and Sales agreement at the time of sales.

Sales contracts that include standard warranty period and disclaimers can be found on our website.

If you have any questions, please contact for our sales person in charge.

HISAKA Plate Heat Exchanger

Installation Manual

Table of Contents



1	Safety Precautions	P1, 2
2	Names of Components	P3
3	Accessories	P4
4	Transport and Packing Style	P4
5	Unloading and Handling	P5
6	Assembly Drawing	P6
7	Installation	P8
8	Piping	P9 to 12
9	Storage/Preservation	P13
10	Inquiries	P13

1 Safety Precautions



Read through this manual carefully before use, and use PHE properly.

















If you have any questions, please inquire with our company.

- Precautions are categorized using the following symbols.

	WARNING	This symbol indicates content where mishandling could result in death or severe injury.
	CAUTION	This symbol indicates content where mishandling could result in injury or property damage.
	NOTE	This symbol indicates important matters and/or useful information.























- Meanings of Symbols

	Indicates items that are "prohibited (something that you must NOT do)".		Indicates items that are "mandatory (something that you must do)".
---	---	---	--

 WARNING			
	NEVER go under hoisted equipment. It could result in death when PHE is dropped, bounced, and rolled over.		Ask for an expert. If inexperienced worker performs unloading, handling and installation, it is more likely that he may cause any accident involving dropping, contact, and rolling over.
	Do NOT loosen PHE's tightening bolts/nuts except for maintenance work. PHE could come apart If tightening bolts/nuts are loosened before installation.		Use an inspection-passed hoisting attachment. Defective hoisting attachments (such as a chain block, shackle and wire) may result in a drop accident.
	Do NOT tow PHE body directly. It could cause PHE to fall down.		Use appropriate hoisting attachments with sufficient strength (such as anchor bolt, metal insert, support, shackle, chain block, wire, etc.) or forklift, after checking PHE weight and its center of gravity. Inappropriate hoisting attachment may cause drop accidents.
	Do NOT change the size, standard, material, and/or type of a foundation bolt /nut. It could result in lack of wind and earthquake resistance strength.		
	Do NOT use a piping gasket to the rubber covering nozzle of PHE. Sealing performance could be decreased and it could be a cause of leaking. In case of metal covering nozzle, piping gasket is required.		Use the lifting holes to hoist. Using any part other than the lifting holes (such as the nozzle, stud bolt, upper guide bar, rail, and guide bar support) to hoist PHE may cause damage.
	In general, do NOT perform pneumatic test for medium and large size PHE. For small size PHE, do not perform pneumatic test at the same pressure as hydrostatic test pressure. When compressed air or nitrogen for pneumatic test is leaked, it is very dangerous since there would be an impact caused by volume expansion in addition to such test pressure. In general, do NOT perform pneumatic test in excess of 0.75 MPaG.		Keep hoisting angle of wire. Be sure that PHE shall be hoisted at 2 or 4 points, with a hoisting angle of 60° or less.
			Take measures to prevent from rolling over, even in case of temporary installation. There may be a risk of damage due to natural disaster such earthquake or storm. PHE needs to be fixed by wire or anchor bolt.
	Do NOT use PHE for lethal service.		Be sure to install PHE on a sufficient grounding. Installation on insufficient grounding and/or improper anchoring may make PHE roll over.
			Perform installation work in strict accordance with your work procedures against natural disaster. Installation on insufficient grounding and/or improper anchoring may make PHE roll over.



CAUTION

 <p>Do NOT touch the side of plate pack and heat transfer plate edge. The edge of a heat transfer plate is very sharp and may cut you. Be sure to wear cut-resistant gloves whenever touching heat transfer plate.</p>	 <p>During erection and construction, cover PHE with a protective sheet to prevent from sparks or falling objects due to work in the surrounding area. Heat transfer plates may be deformed or lose their strength if hit by a falling object. Gaskets may be melted or reduce the sealing performance if hit by a spark.</p>
 <p>Do NOT place objects on plate pack. It may cause deformation of heat transfer plate. Falling object may cause injury during operation.</p>	 <p>Secure working space around PHE. Adequate piping design is required, taking into account the working space for disassembly and tightening device.</p>
 <p>Do NOT make heat transfer plate edge deform by contacting with surrounding object. Deformation of the heat transfer plate may cause damage on plate gasket and result in leakage.</p>	 <p>Clean the piping inside before connection. Clean piping thoroughly so that no debris enters PHE.</p>
 <p>Do NOT shorten guide bar by cutting. It makes disassembling of PHE impossible.</p>	 <p>Ask for an expert to perform piping and wiring work with the Assembly Drawing and Wiring Diagram. If inexperienced worker performs piping / wiring work unloading, there is possibility that he may cause construction error. Furthermore, connection error may lead to performance shortage or failure.</p>
 <p>In general, do NOT remove stud bolt of connection. It may cause damage on the threads. Stud bolt is to be removed very carefully not to make any damage on the threads of both stud bolt and its hole at your own risk, only when it is absolutely necessary.</p>	 <p>Install sufficient support for the piping connected to PHE. Large piping load to PHE may cause its frame to deform or leak.</p>
 <p>Do NOT weld or attach any piping support onto the frame, guide bar, and/or guide bar support. Such welding causes thermal damage on plate gaskets and attached parts may interrupt handling when disassembling.</p>	 <p>Select a flange gasket material suitable for fluid's specifications. Flange gasket is required for metal covering connection.</p>
 <p>Do NOT weld piping with flange being connected to PHE. Such welding causes gasket deterioration due to thermal damage, by which it may cause leakage.</p>	 <p>Install safety apparatus on the connected piping as necessary. Install safety apparatus compliant with various standards or regulations to the piping you connect.</p>
 <p>Do NOT enter debris or foreign materials into PHE. Heat transfer plates clearance is so narrow as to be easily clogged by debris or foreign materials. When flushing the piping, take measures such as installing a temporary strainer at the inlet piping or bypassing PHE in order to prevent debris or foreign materials from entering PHE.</p>	 <p>Install a ground wire (for models where an optional earth lug is affixed). Incomplete ground wire may cause electric shock.</p>
 <p>Do NOT start and stop the pump frequently (in a short time). During commissioning, pay attention to time duration of pump start/stop, or there would be leakage due to difficulty of gasket restoration caused by temperature and pressure variation. After stopping, min. 3 minutes is recommended to restart.</p>	 <p>Ensure no pressure or fluid remaining inside before disassembling PHE and/or removing piping. Blowing out of PHE may cause severe injuries.</p>
 <p>Do NOT operate in excess of the design conditions (fluid, temperature, flow rate, pressure, tightening length, etc.). It may cause deformation of the heat transfer plates or leakage. Also, the required performance may not be achieved.</p>	 <p>Please take measures such as preparing adequate insulation and grounding and so on. Stray current during welding work can cause sparks and it may become lead to damage of the heat exchanger.</p>
 <p>Do NOT apply instantaneous negative pressure. Drawdown may occur if instantaneous negative pressure is applied to PHE by pump stop or valve closing, or heat transfer plates deformation may also.</p>	
 <p>Do not operation under the abnormal vibration (resonance). When abnormal vibration (resonance) or abnormal sound occurs during the operation, stop operation immediately and recheck the installation or operation condition. It may cause of breakage.</p>	
 <p>Do NOT freeze. Drain out completely to avoid freezing in case of preservation in cold areas.</p>	

2 Names of Components

PHE consists of the following parts.

[NOTE]

- Refer to the "Plate Arrangement Drawing" for equipment specifications.

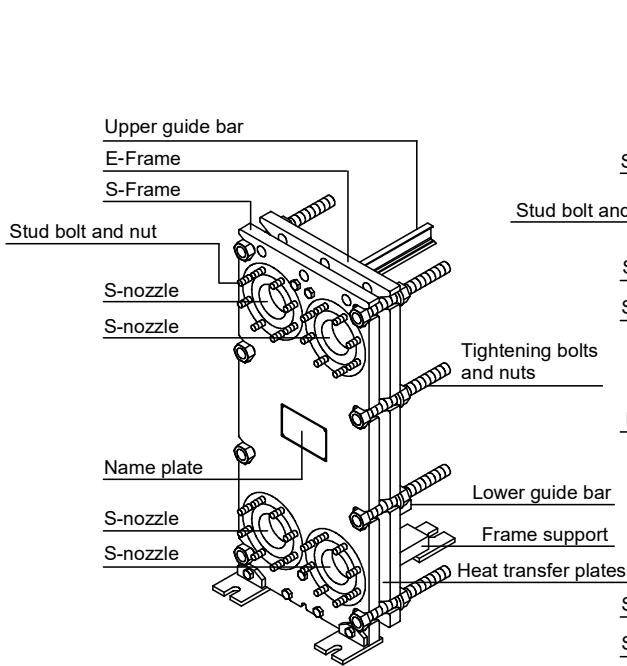

Fig. 2-1 J Type Heat Exchanger

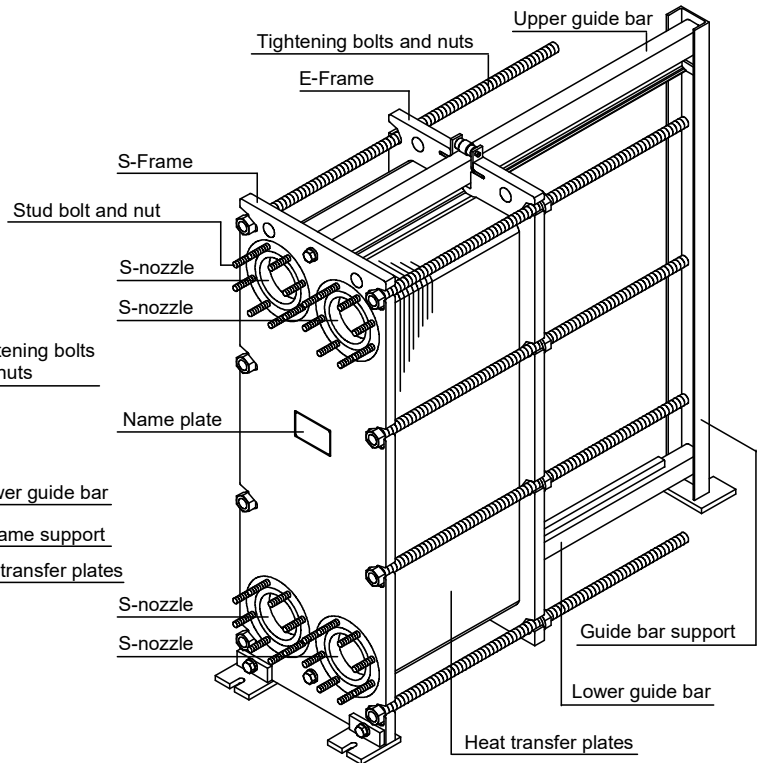

Fig. 2-2 P Type Heat Exchanger

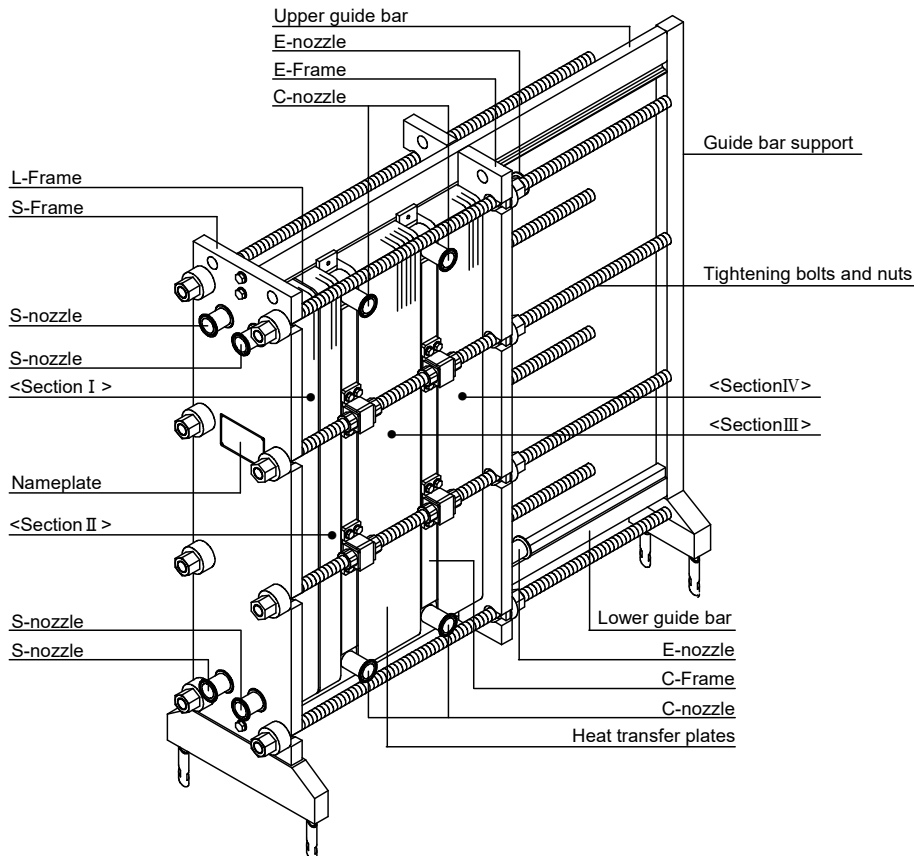

Fig. 2-3 BP2CL Type Heat Exchanger

3 Accessories

Accessories of HISAKA Plate Heat Exchangers are optional parts.

Please inquire with our company's sales representative if you require a ratchet spanner, anchor bolt, thermometer, pressure gauge....etc.

4 Transport and Packing Style

Packing style of HISAKA Plate Heat Exchanger are as follows.

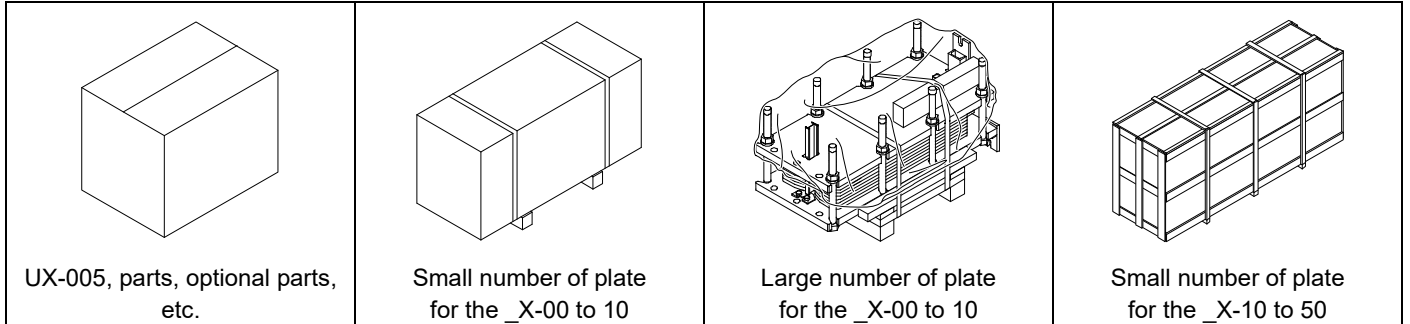

Fig. 4-1
Cardboard packing

Fig. 4-2
Cardboard packing with skid

Fig. 4-3
Plastic covered packaging with skid

Fig. 4-4
Crate packing with skid

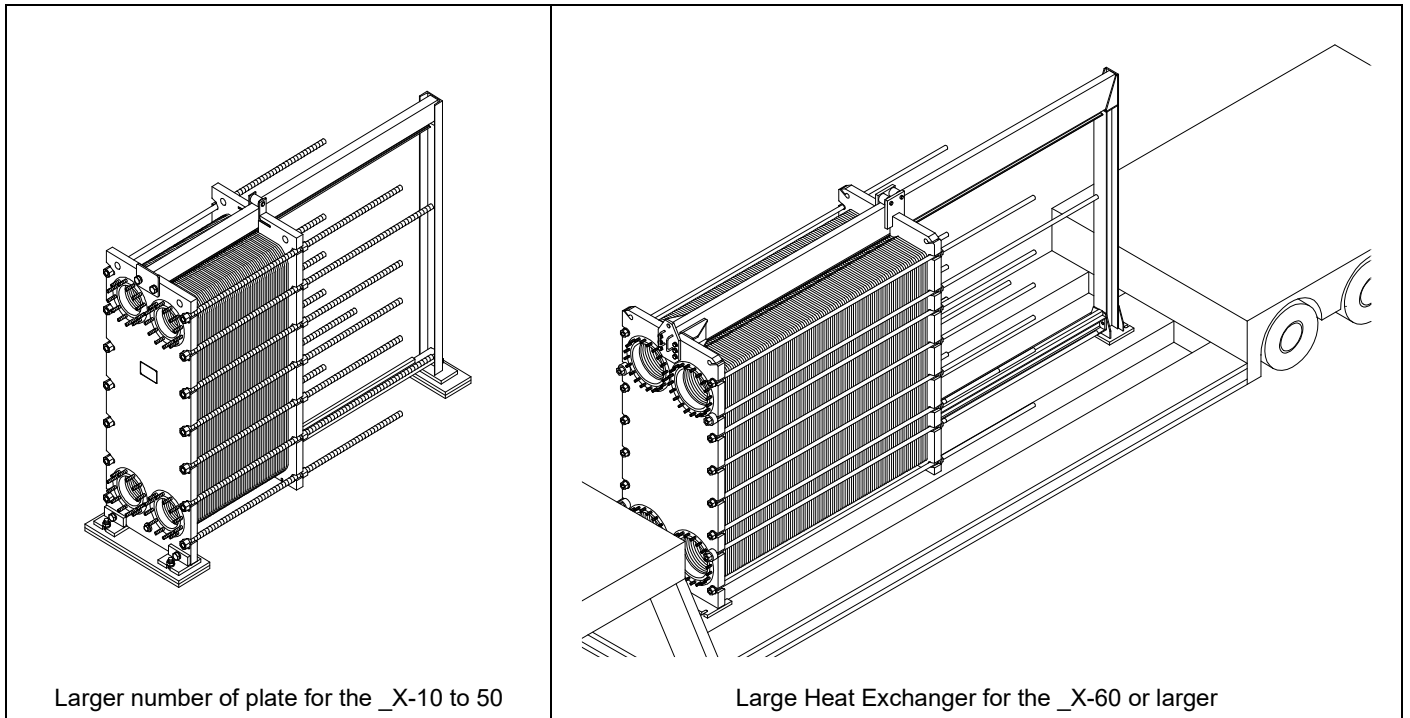

Fig. 4-5 Without Cover, With Skid

Fig. 4-6 Without Cover/Skid (* With canvas cover during transportation.)

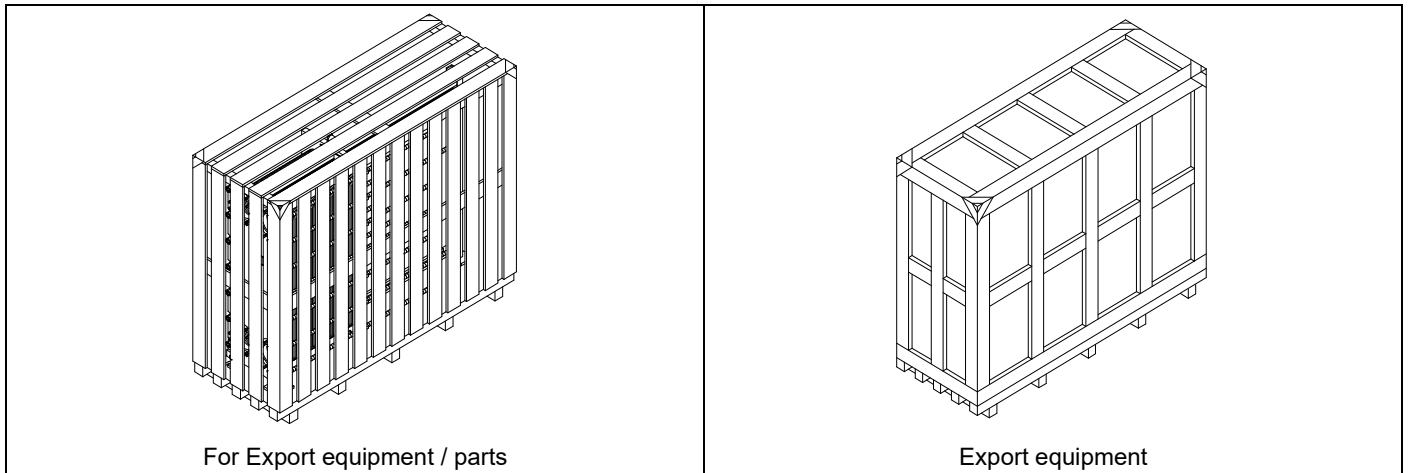

Fig. 4-7 Crate

Fig. 4-8 Case

5 Unloading and Handling

- 5.1 Check the packing / empty weight /dimension of HISAKA Plate Heat Exchanger. (Refer to Assembly Drawing and Nameplate)
- 5.2 Check the following Figs.
- 5.3 Unloading with appropriate equipment within its allowance.
- 5.4 In case of towing equipment: Handle the equipment with safe using by TIR roller.
- 5.5 MFG No. and Model shall be informed for any inquiry

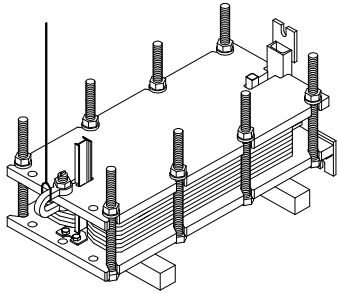

Fig. 5-1 Lifting - 1-point hoisting (Small size)

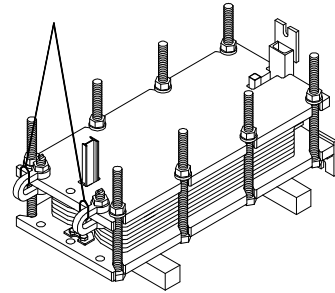

Fig. 5-2 Lifting - 2-point hoisting (Small and Medium size)

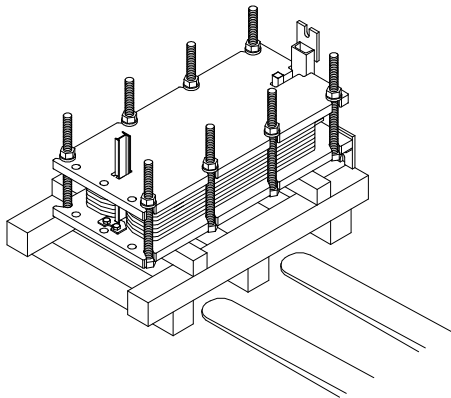

Fig. 5-3 By forklift (Small and Medium size)

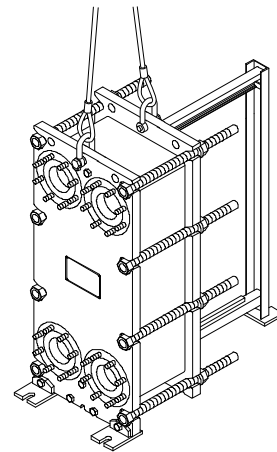

Fig. 5-4 By crane - 2-point hoisting (Small and Medium size)

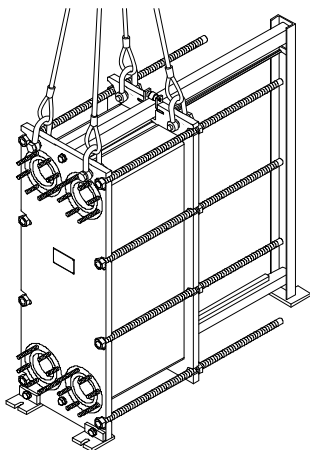

Fig. 5-5 By crane - 4-point hoisting (Medium and Large size)

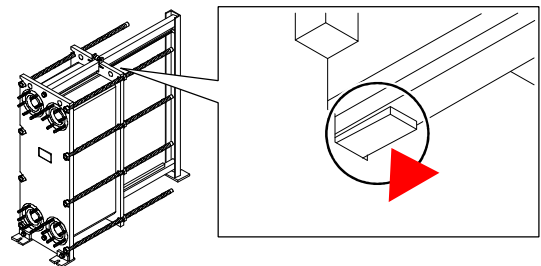

Fig. 5-6 Cotter

To prevent lifting up of E-Frame, cotter is used for hoisting large model of PHE.
Remove it during maintenance for smooth disassembling and keep it.

[CAUTION]



- A little water used at hydrostatic test might remain in PHE.
Remind the remaining water may come out from nozzle during hoisting.
- ※ Hot air drying option is exception.

[NOTE]

<Disposal of packing material>

- It shall be disposed or recycled according to relevant, local regulations as industrial wastes.

7 Installation

7-1 Before Installation

(1) Required maintenance space

Refer to the figure below and Table 7-1 for required space of construction, inspection, and maintenance.

Comply with municipal fire prevention regulations regarding the minimum clearance for the equipment and the other equipment.

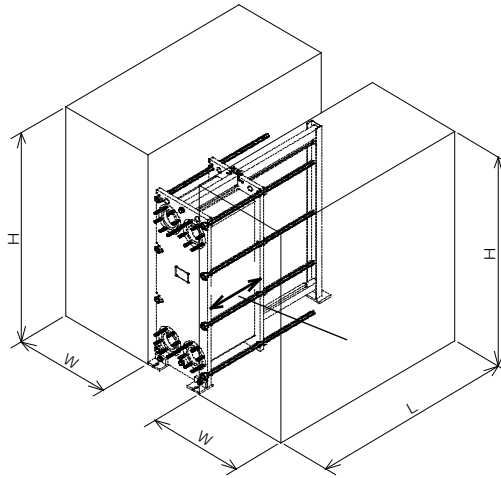

Fig. 7-1 Maintenance space

Table 7-1 Required maintenance space (Recommended)

Model		Width: W [mm]	Length: L [mm]	Height: H [mm]
Small size	UX-005/01/10, LX-00/10, CX(W)-01/03/10/20 RX-00/10, WX-10, SX-10, ZEX-20(S/M)	Recommendation 600 or more (Min. 400)	1,000 *1	1,300
Medium size	EX-11/15/16, UX-20/30/30L/40 LX-20/30/40/50/50S, RX-30/50 SX-20/30S/30/40, WX-50, GX-20/50 NX-30/50, FX-01/10, WH-30	Recommendation 1,000 and over (Min. 800)	Full length of PHE *1	2,300 *2
Large size	UX-80/90/100(R)/110R/130(R)/160 RX-70/90, JX-600, LX-90, DXC-650 SX-70/80/90(S/M/L) WX-90, YX-80/83, NX-90 FX-03/05/30	Recommendation 1,500 and over (Min. 1,000)	Full length of PHE + 600 in front *1	Height of PHE *3
	YX-80 or YX-83 with an E-nozzle	Recommendation 1,000 and over (Min. 800)	Full length of PHE + 1,000 behind	2,300

*1. If an inner strainer is included, consider pull-out dimensions behind PHE. For an estimation, the pull-out dimension is "tightening length + S-Frame thickness + E-Frame thickness + maintenance space" behind the E-Frame.

*2. Recommended maintenance space is height of PHE, If the height of PHE exceeds 2300mm.

*3. If automatic tightening device is used for PHE, extra 1,500 mm of space above PHE is required.

(2) Tolerance for installation

- Width clearance of foundation hole (notch): 1.0 to 1.5 mm
- Length clearance of foundation hole (notch): 10 to 15 mm

[NOTE]

- In case of contacting with foundation hole (notch) to foundation bolts, the tolerance for installation will be decreased.
- Refer to the "Assembly Drawing (Foundation Drawing)" for installation dimensions of foundation bolts.

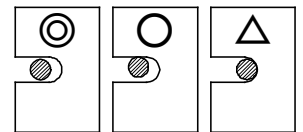

7-2 Installation

Install PHE on a firm foundation and maintain the horizontal level.

If there is a gap between the foundation surface and the base plate, fill in the gap using liner. Fix the base plate tightly using foundation bolts or anchor bolts and nuts.

8 Piping

8-1 Notes for Piping Design

- (1) Do not use a piping gasket to the rubber covering nozzle.
A metal covering nozzle requires a piping gasket.

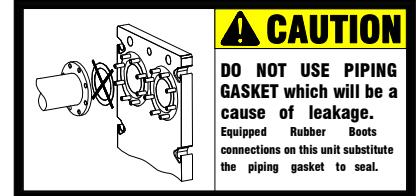

Fig. 8-1 Prohibited use of piping gasket

- (2) Permanently install a strainer on the inlet in case fluid contains foreign material. Even for fluid that does not contain foreign material, install a temporary strainer directly after piping construction and perform sufficient flushing. Please select the strainer hole size refer to Table 8-1 below.

Table 8-1 Recommended strainer hole size (reference)

Model	Hole size [mm]	Model	Hole size [mm]	Model	Hole size [mm]
UX-005	1.4	SX-10	1.1	FX-01	1.8
UX-01	1.8	SX-20	1.1	FX-10	1.8
UX-10	1.5	SX-30S,30	1.4	FX-03	1.8
UX-20	1.9	SX-41, 47, 44	1.7	FX-05	2.7
UX-30,30L	1.8	SX-43, 49, 45	1.1	FX-30	2.1
UX-40	2.5	SX-71, 77, 74	1.5	EX-11	2.8
UX-80	3.3	SX-73, 78, 74	1.4	EX-15	2.9
UX-90	3.1	SX-80 S/M/L	2.1	EX-16	2.8
UX-100	3.1	SX-90 S/M/L	2.4	YX-80A	1.7
UX-100R	2.7	RX-00	1.9	YX-80B	2.0
UX-110R	2.7	RX-11, 19, 12	1.8	YX-83A	1.7
UX-130	3.1	RX-13, 18, 14	1.9	YX-83B	2.0
UX-130R	2.7	RX-30	2.1	WX-13, 18, 14	1.9
UX-160	2.3	RX-50	2.4	WX-11, 19, 12	3.6
LX-00	2.5	RX-70	2.9	WX-50	2.5
LX-10	2.9	RX-90	2.7	WX-90	3.1
LX-20	3.6	GX-20H	3.6	WH-30	1.7
LX-30	3.3	GX-20M	4.0	NX-30	1.9
LX-40	4.0	GX-20L	8.0	NX-50	2.0
LX-50S,50	3.3	GX-50H	2.8	NX-90	2.4
LX-90	2.7	GX-50M	3.2	DXC-650	2.8
CX(W)-01	1.5	GX-50L	6.0		
CX-03	2.1	ZEX-20 S/M	2.1		
CX-10	1.8				
CX-21	1.9				
CX-23	2.9				

*8-1. The above hole sizes are for reference. The inner strainer installed in PHE mainly for marine use(sea water use) may differ from the above hole sizes in consideration of cleaning frequency.

- (3) Install support with sufficient strength for the piping connected to each nozzle. However, do not install fixed piping or piping support inside the maintenance space.
- (4) The maximum allowable flow velocity for PHE port holes is 7 m/s, limited to fluids that are not corrosive or erosive. In case piping with the same diameter as PHE port hole is used, erosion may occur on the inside surface of the piping because the flow velocity in PHE is applied faster than in piping in general. Please install a reducer appropriately to connect to PHE, after design of piping size for an appropriate flow velocity.
- (5) Arrange three or more short piping to be connected to each nozzle in order to remove each pipe. In general, the nozzle stud bolts cannot be removed, so plan to remove the second short pipe and thereafter.
- (6) Use an expansion joint for the nozzle of C-Frame or E-Frame, since such PHE may be tightened to MIN dimensions.

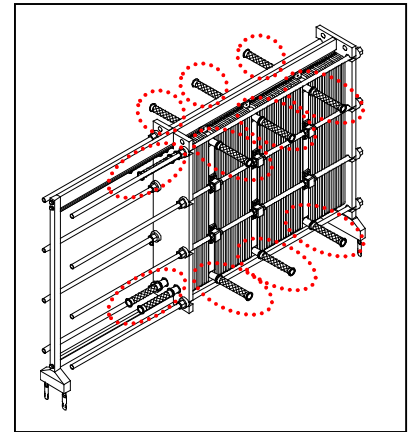

- (7) When using ring gaskets or spiral wound gaskets on the market, check the "Assembly Drawing" first and purchase the gaskets with specified external dimensions in order to avoid interference between stud bolts and gaskets.

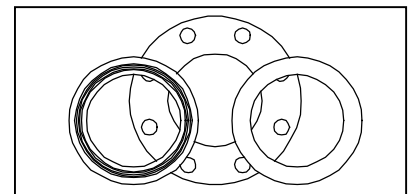

- (8) Be sure to fill steam from the upper nozzles (S1, S2, E1, E2, C1, C2)(*8-2). Use the lower nozzles (S3, S4, E3, E4, C3, C4) as inlets for fluids that contain large amounts of debris or foreign material, such as sea water.

*8-2. DXC-650 : As per drawing instructions.

- (9) Install air vent valve on the piping connected to the upper nozzles (S1, S2, E1, E2, C1, C2), and drain valve on piping connected to the lower nozzles (S3, S4, E3, E4, C3, C4).
- (10) Arrange the piping enough to drain out when using saturated steam. Do not arrange the outlet piping over the height equal to steam head pressure.

- (11) In case of upward piping, drawdown will occur during maintenance, so install a foot valve and a feeding line.

- (12) Drain out completely to avoid freezing in case of preservation for long term in cold areas.

- (13) Install safety apparatus compliant with various standards or regulations to the piping you connect.

- (14) If PHE model is NX-30/NX-50, nozzles for leak detection are installed and kept open.

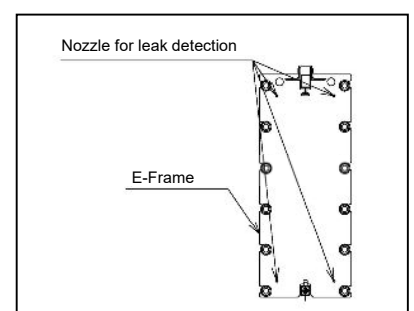

8-2 Before Piping

- (1) When the pipe attached to the E frame side of the heat exchanger is designed, please design it to correspond to both maximum and minimums of tightening length.
- (2) After referring to the Assembly Drawing, check below points;
 - 1) Piping to be connected and the fluid are correct.
If the left and right nozzles are made of different materials, the piping connections cannot be switched between left and right.
 - 2) Inlet and outlet ports are correct.
Do not connect the steam inlet to a lower nozzle.
- (3) Curing seal, plywood, or iron sheet are installed on each PHE nozzle for shipping.
Remove them before connecting piping.
- (4) Check that there is no debris inside PHE nozzles and the piping to be connected.
- (5) Check that the ratchet spanner or automatic tightening device does not contact with the piping and/or insulation.

8-3 Example for Piping

Refer to the examples of GOOD or NG piping shown in Figs. 8-1 to 8-7 below.

*1. Piping with hatching lines indicates fixed piping. *2. Piping with cross hatching lines indicates expansion joints.

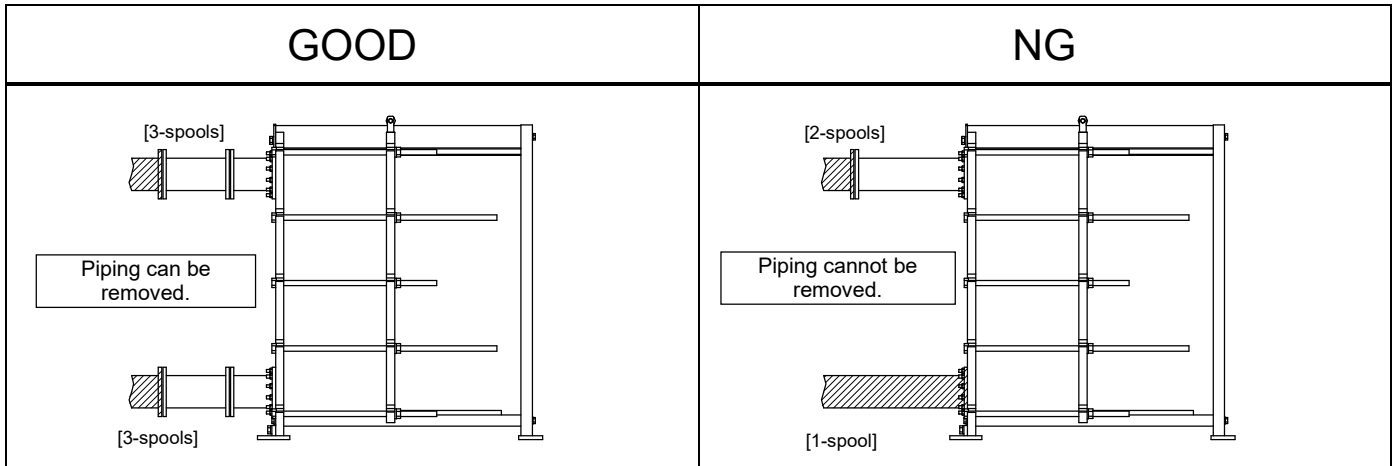

Fig. 8-1 Arrange the piping to be connected to each nozzle with three or more spools

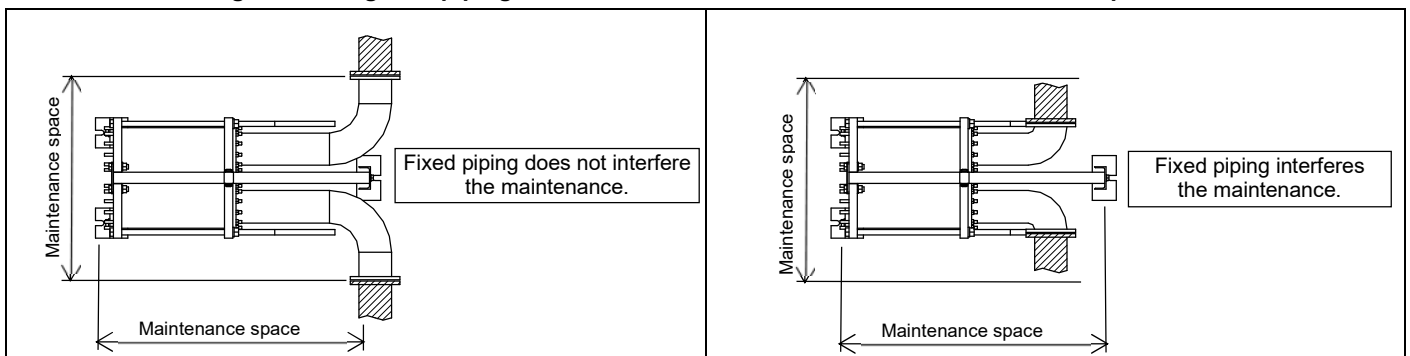

Fig. 8-2 Do not install fixed piping in the maintenance space (Bending piping)

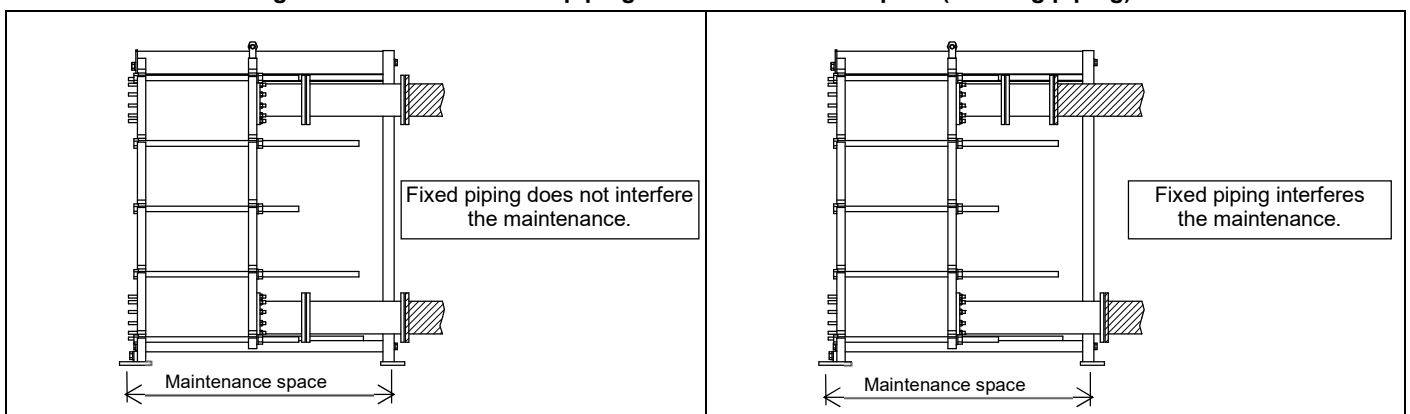

Fig. 8-3 Do not install fixed piping in the maintenance space (Straight piping)

*1. Piping with hatching lines indicates fixed piping. *2. Piping with cross hatching lines indicates expansion joints.

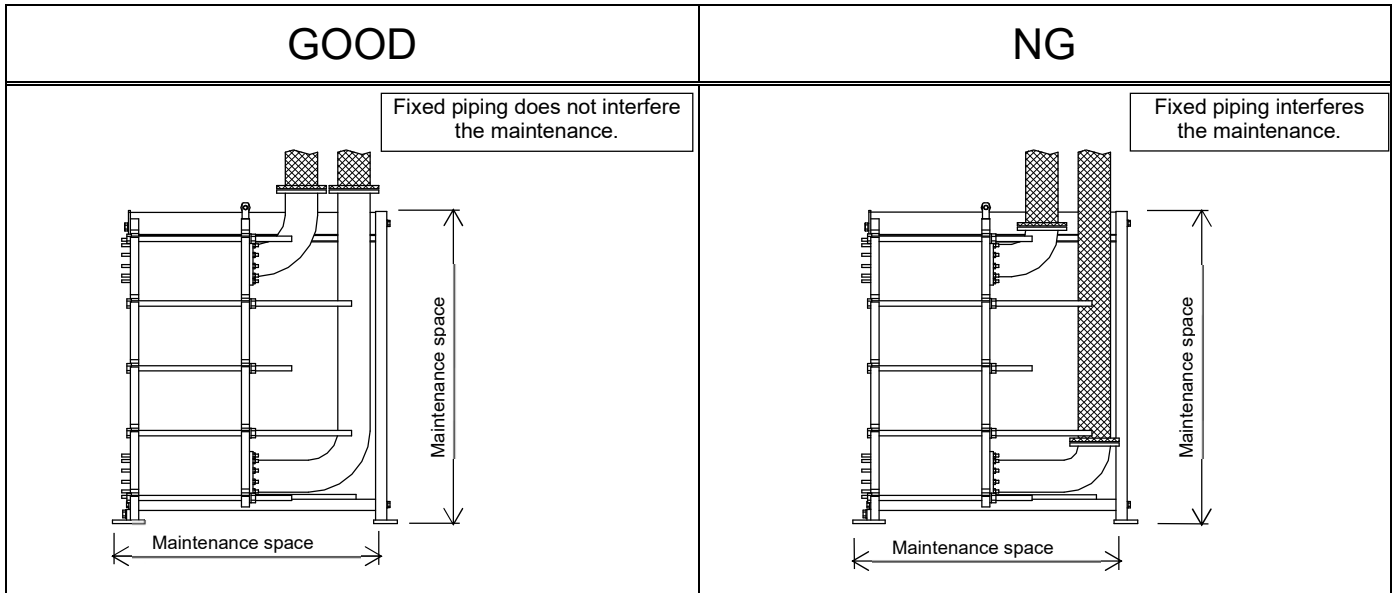

Fig. 8-4 Do not install fixed piping in the maintenance space (Upward piping)

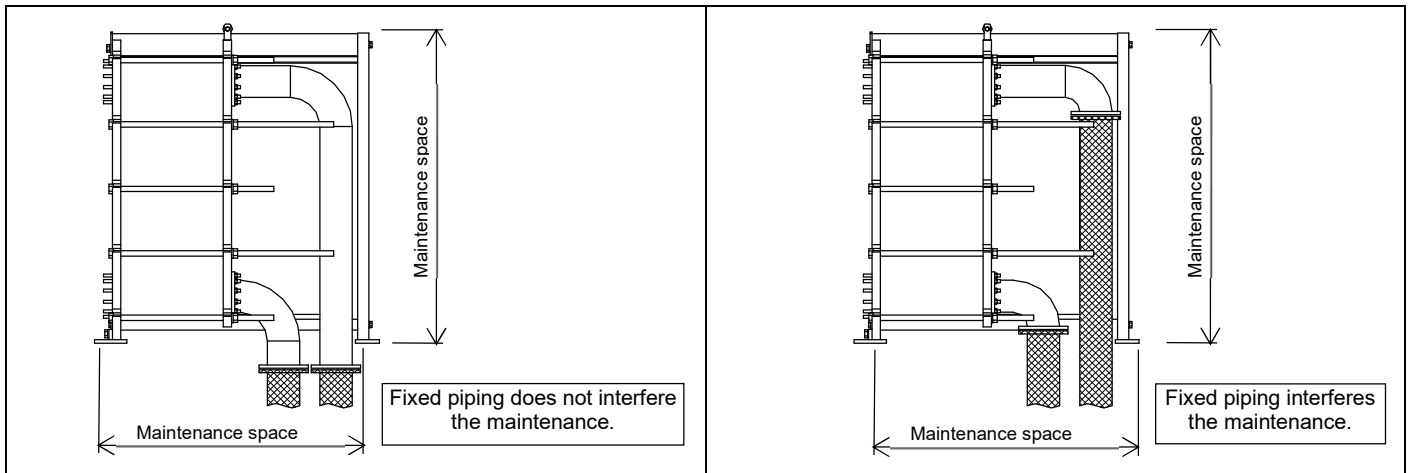

Fig. 8-5 Do not install fixed piping in the maintenance space (Downward piping)

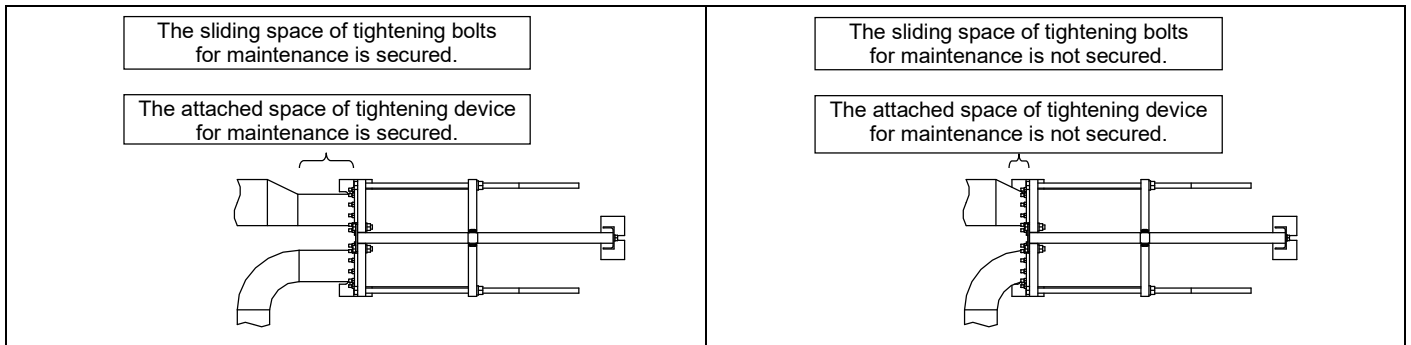

Fig. 8-6 Secure enough clearance between each nozzle and reducer, elbow pipe

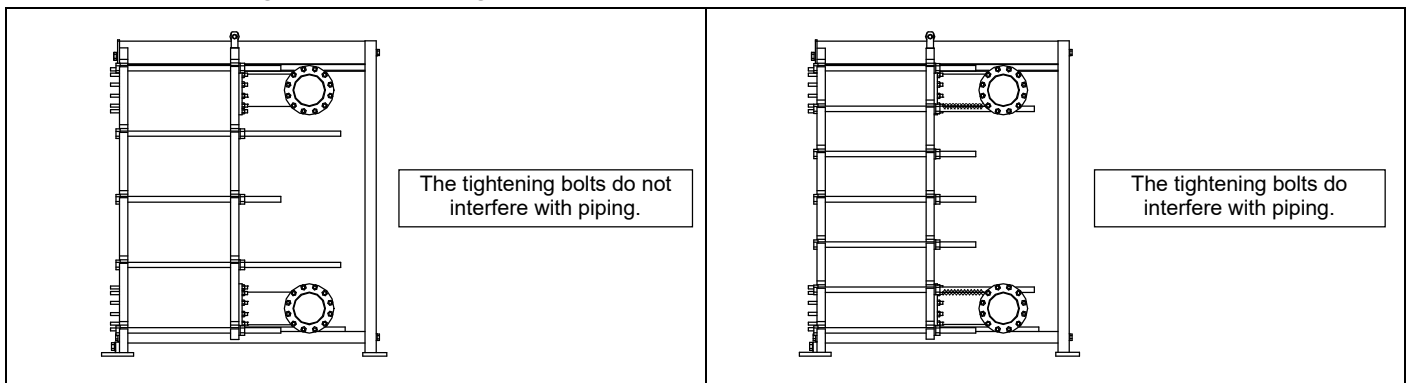

Fig. 8-7 Caution for tightening bolts interfering with piping

9 Storage/Preservation

Follow the below cautions when PHE is stored a long term until the operation.



[CAUTION]: Do NOT remain a liquid in PHE.

- To prevent clogging and corrosion in PHE chambers due to foreign material or dirt.
- To prevent volume expansion or freezing in PHE chambers.



[CAUTION]: Cover PHE with a protective sheet to shade a light.

- To protect PHE from impact or damage caused by external factors.
- To protect PHE from dirt and dust.

10 Inquiries

Contact info for inquiries

HISAKA WORKS, LTD., Heat Exchanger Div., Sales Department *10-1

Konoike Plant: 2-1-48, Higashi-konoike-cho, Higashi-osaka City, Osaka 578-0973 Japan	Tel : +81-72-966-9601	 Japan locations
	Fax : +81-72-966-8923	
Tokyo Branch office: 1-19-8, Kyobashi, Chuo-ku, Tokyo 104-0031 Japan	Tel : +81-3-5250-0760	
	Fax : +81-3-3562-2760	

*10-1. Other Japan locations can be referred 2D code.

URL : https://www.hisaka.co.jp/english/company_info/access.html

Global Network

Overseas locations can be referred 2D code. URL : https://www.hisaka.co.jp/english/company_info/access_world.html	 Overseas locations
--	---

[NOTE]

- Please inform us the "MFG. Number" and "Model" described on the nameplate or Plate Arrangement Drawing and Assembly Drawing.

- For more information
Hisaka Works, Ltd. official homepage (<https://www.hisaka.co.jp/english/>).

- Customer's memo
Please fill in the table below with PHE information.

Item Number		
MFG. Number		
Model		
Qty		
Date MFG.		
Maintenance records		
Memo		



HISAKA WORKS, LTD. HEAT EXCHANGER DIVISION

Hisaka Works, Ltd., Heat Exchanger Division acquires both ISO9001 and ISO14001 certification.

HE-ME0012R27