

Plate Heat Exchanger

MAINTENANCE

GUIDE HISAKA Plate Heat Exchanger Maintenance Guide



HISAKA

Thank you for choosing the HISAKA plate heat exchanger.

The HISAKA plate heat exchanger is a relatively trouble free, high performance equipment, but proper maintenance will further increase its reliability, and extend its life.

This booklet is a compilation of knowledge gathered over the years at HISAKA, as the sole domestic plate type heat exchanger manufacturer in Japan. Please utilize the booklet to avoid troubles and to improve productivity of the plate heat exchanger.

HISAKA WORKS, LTD.
Heat Exchanger Division

- 1— Construction of Plate Heat Exchanger Mechanism ●4
- 2— Maintenance for Equipment ●6
 - Performance ●7
- 3— Maintenance..... ●8
 - Spare parts ●8
 - Deterioration of gaskets..... ●12
 - Cleaning methods..... ●14
- 4— Introduction of Maintenance Services ●6
 - "Full Service Package" ●16
 - Other services..... ●17
- 5— Fault Detection ●18
 - 5-1 Scaling..... ●18
 - Langelier saturation index and scaling ●18
 - Marine growth..... ●20
 - Seawater strainer..... ●22
 - 5-2 Corrosion of Plate ●24
 - General corrosion ●24
 - Pitting corrosion ●25
 - Crevice corrosion..... ●27
 - Erosion corrosion..... ●29
 - Stress corrosion cracking ●30
 - 5-3 Other Fault Detections..... ●32
 - Fatigue crack ●32
 - Plate deformation..... ●33
- 6— Overhauling ●34
- 7— To Extend the Lifetime of Your Heat Exchanger ●35

1— Construction of Plate Heat Exchanger Mechanism



Ever since its debut as a product in 1953, HISAKA plate heat exchanger has been highly reputed for its "high performance", "lightweight, compact design", "energy saving" and "easy maintenance characteristics", and have been widely applied in a variety of industries including chemical, HVAC (heating, ventilation, air conditioning), food, power station, shipbuilding, steel, mining, semiconductors and for environmental applications.

Construction

The heat transfer plate, is manufactured by press forming thin sheets of corrosion-resistant metals such as stainless steel and titanium. A plate element consists of this heat transfer plate with its peripheral area sealed with a synthetic rubber gasket. In the plate heat exchanger, the required number of plate elements are suspended on a guide bar, and sandwiched between fixed steel frame and movable steel frame and tightened together with bolts/nuts. There are over 40 types of plate elements, and each are

precisely designed so that they work maximum performance in each process. The heat transfer plate and gasket are high precision formed products, and tightened with uniform force in order to achieve high sealing performance.

Construction plate heat exchanger

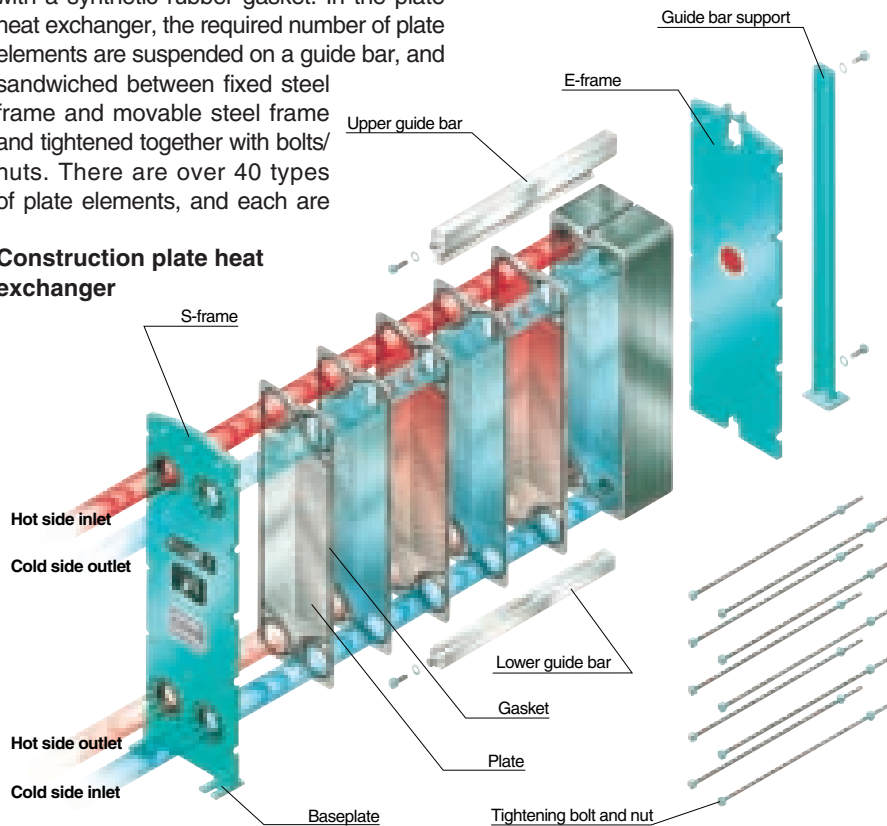

Tightening lengths

The dimension between the fixed and movable frame is called the tightening dimension, and the unit is tightened between the maximum dimension and the minimum dimension. The tightening lengths is shown on the assembly drawings and on the nameplate of the unit.

Manufacturing number

When contacting us in regards to maintenance, please notify us of the manufacturing number. It is possible to understand all specification of the unit, just with the manufacturing number. The manufacturing number is shown on the drawings and on the nameplate on the unit.

<p>↑ Glued to the E-frame outside.</p>	<p>↑ Glued to the both E-frame and packing case outside.</p>
<p>↑ Glued to the E-frame inside.</p>	<p>↑ Glued to the package Instruction manual in inside.</p>

Tightening Length

Manufacturing Number



SPARE PARTS & MAINTENANCE

TEL: +81-72-966-9601

FAX: +81-72-966-9602

→ Please let us know the Mfg No.

HISAKA WORKS, LTD. HEAT EXCHANGER DIVISION
CUSTOMER SUPPORT
2-1-48, Higashi Konokuchi, Higashi Osaka City, 578-0973 Osaka Japan

↑ Maintenance call sticker

This sticker which is labeled on to each unit shows our maintenance service number.

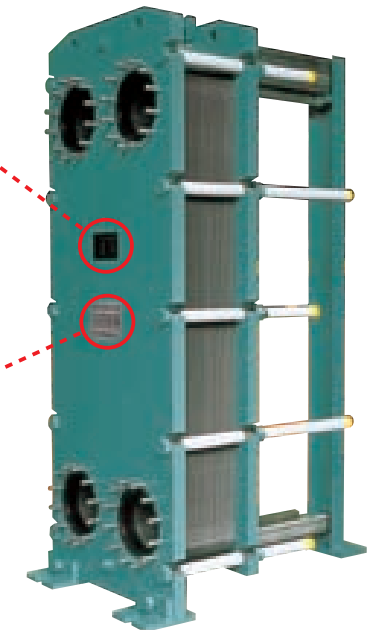

2— Maintenance for Equipment



There are no moving parts on a plate heat exchanger, making it a device with a low number of component parts, and relatively free of malfunctions or other trouble. However, with extended periods of operation, there may be deterioration of gaskets, scaling by water residue and other debris, and corrosion and cracking may occur. If left as is, this will lead to a reduction in performance, intermixing of fluids and leakages, and can ultimately lead to stopping of the unit and the entire plant. In order to prevent this, it is necessary to periodically disassemble the unit, and perform inspection and cleaning.

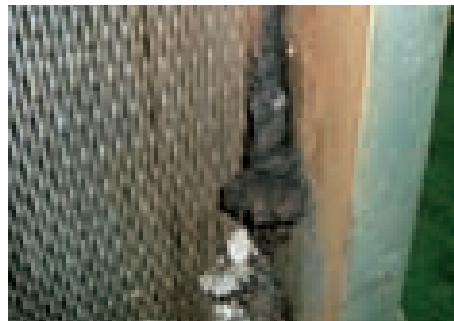
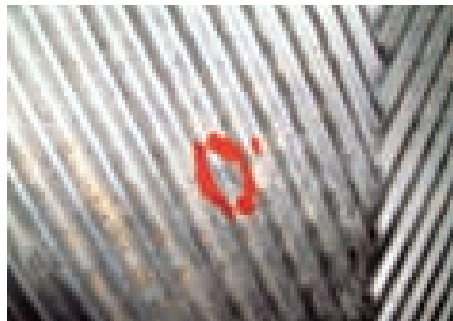

↑ Cracking visual inspection (top)
Cracking detection by dye penetration test (bottom)

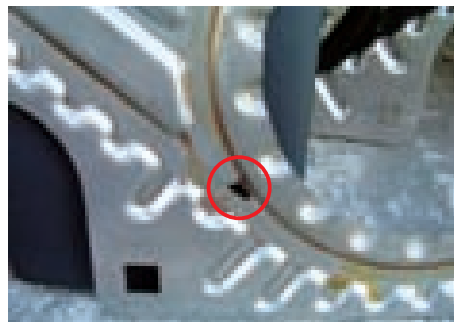

↑ Heat exchanger left alone without changing the gasket (top), crevice corrosion occurring at the gasket line (bottom)

Main reasons for reduction in performance and leakages of the plate heat exchanger, include the scaling by water inside the heat exchanger and deterioration of the gasket due to extended use. For the problem with scaling by water residue, we recommend that decreasing the performance be monitored, and to perform periodic opening and cleaning accordingly.



↑ Scale accumulated on the plate surface

■ Performance

When the heat exchanger is used for extended lengths of time, scale will adhere inside, and the overall heat transfer coefficient will drop over time. The initial performance is restored by periodically opening and cleaning the unit.



↑ Hard scale inside the plates

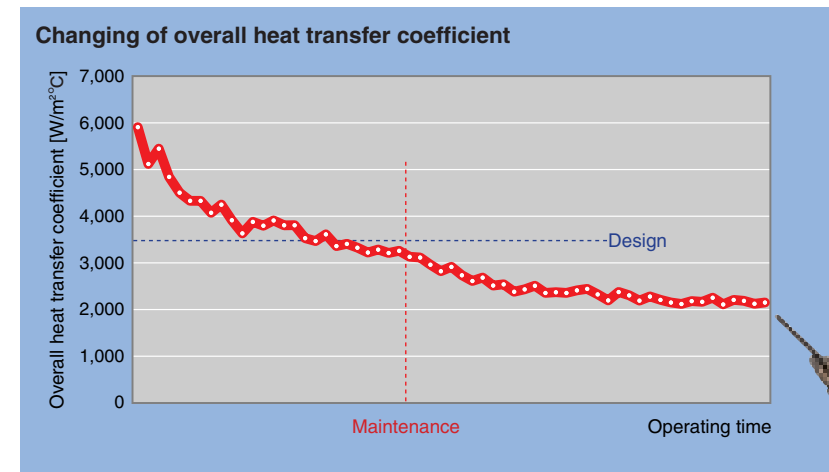

3— Maintenance

The maintenance of the plate heat exchanger is largely divided into spare parts and plate cleaning. Spare parts consist of gaskets, plates, and frames, and methods of plate cleaning include mechanical cleaning and chemical cleaning.

■ Spare parts

<Gasket>

The reliability of the gaskets has been proven through years of research, experience, evaluation and actual performance at HISAKA. Though a plate gasket seems simple, there are many technical ideas in the shape, thickness, width, material, and are nothing like the ordinary piping flange gaskets punched out from a rubber sheet material.

The selection of the synthetic rubber compound that is provided as the product, is closely evaluated for its cost, chemical resistance, heat resistance, and anti cracking performance. From several thousand compounds, we select those that clear these evaluation factors at the highest level. In addition, they are repeatedly checked in various endurance tests before the final decision, and are vulcanized and mold formed in precision dies that take into account amount of shrinkage for the final dimensions.

The gaskets are the only consumable part in the maintenance of plate heat exchangers. A lot number is shown on the gasket, making it possible to identify the date of manufacture, the die used, and material. For the material, color marking is utilized to make it easy to identify visually.

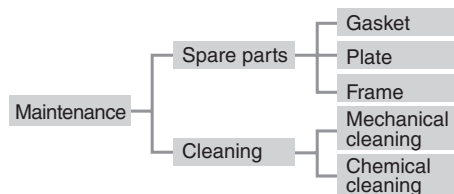

↑ With the lot number and yellow marking, it can be confirmed that this material is NBR.

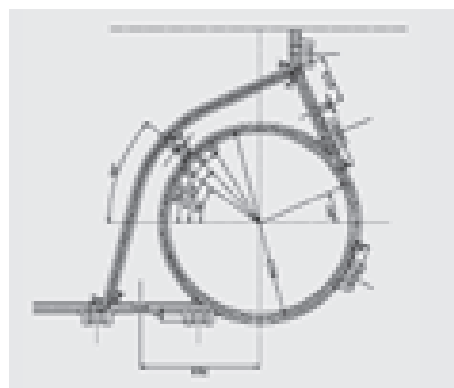

↑ Gaskets are manufactured based on precision design.

Gasket material symbols and list of colors

Material		Color marking	Product name
Abbreviation	Symbol		
NBR	H	Yellow, 1 point	Nitrile-butadiene rubber
G-NBR	NBR	Yellow, 1 point	
	NBR	Yellow, 2 points	
	NBR	Yellow 1, Green 1	
NBR for Food	HF	Pink, 1 point	Food approved NBR
	NBR	Yellow, 2 points	
EPDM	NE	Pink, 2 point	Ethylene-propylene Diene-Methylene Linkage
	YE	Pink, 2 point	
	E	Pink, 2 point	
	EE	Pink, 2 point	
	E	Green, 1 point	
G-EPDM	EPDM	Pink, 2 points	
	E	Pink, 2 points	
EPDM for Food	NE	Pink, 2 points	Food approved EPDM
	EPDM	Pink, 2 points	
R-EPDM	ER	Green, 2 points	High temperature EPDM
IIR	V	Blue, 1 point	Chloro-isobutene-isoprene rubber
G-IIR	IIR	Red, 2 points	Butyl (isobutene-isoprene) rubber
N-IIR	T	Brown, 1 point	
FPM	FV	N. A.	Fluorinated rubber
R-FPM	RV	White, 1 point	
G-FPM	FPM	Purple, 1 point	
	FPM	Purple 1, White 1	
	FPM	Purple, 4 points	
Si	SS	N. A.	Silicone rubber

The symbols and colors are current as of April 2005. For those that do not appear on this list, please contact us.

Guideline for regasketing

Operating temperature	Guideline for regasketing
100°C ≤	1-3 years
30°C ≤ and 100°C	5-7 years
≤ 30°C	within 7-10 years

As an additional condition, if there are applicable laws and regulations such as for Japanese Pressure Vessel Class 1 and high pressure gas safety laws, perform disassembly and inspection according to the applicable legislation or regulation. Refer to the separate page for regasketing. Make overall considerations including the corrosion resistance of the gasket for the fluid as well, and set a regasketing period.

3— Maintenance



<Plate>

The heat transfer plate is formed in the press facilities of HISAKA which have the largest 40,000 ton press machine in the world and other unique press machine. In order to press the plates under optimal conditions, the plate die is checked every few thousand to 10 thousand shots.

The plates in the plate heat exchanger are thin and of 0.5mm to 1.0mm in thickness. In order to press these thin plates without press defects such as flaw, necking, the high pressing tools design and manufacturing technology, and pressing technology of HISAKA are absolutely essential.

These plates are printed with a lot number using an electronic marker as well as gaskets, and the plate thickness, material,

and manufacturing date can be found, and makes it possible to track down the mill certificate plate material by mill certificate.



↑ Lot number
Indicates that model LX-026, S316 is made of SUS316.

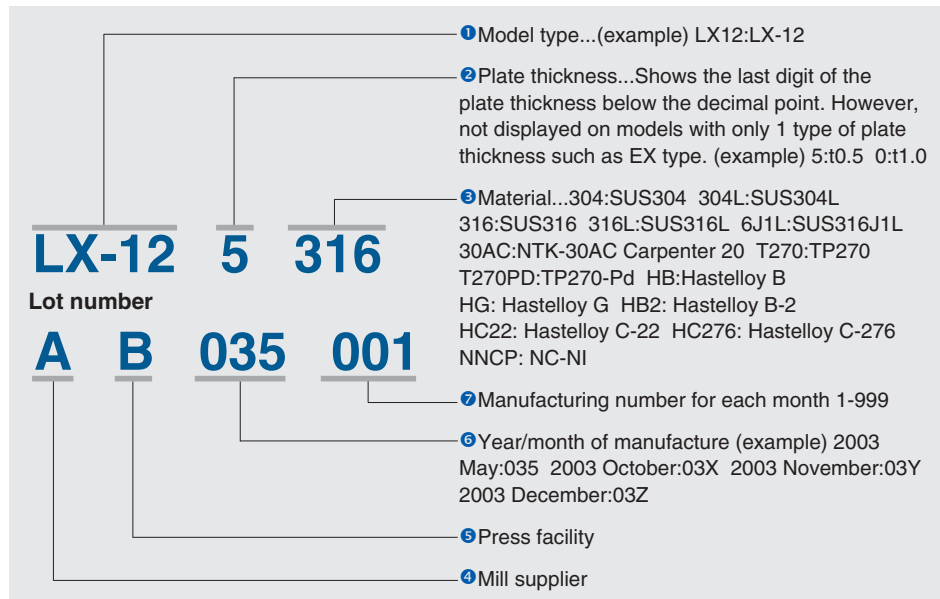

<Frame>

The frame plate is a pressure retaining part that maintains the sealing of the unit by tightening together the plates with uniform tightening force. Because of this, if there is corrosion or deformation, it will require periodic overhaul. There is also a model with rubber lined (NJ/NP type) on the connection holes of the frame plate to prevent the carbon steel material from corrosion by fluid. This rubber lined is called a rubber boot, and requires replacement if deterioration is found.

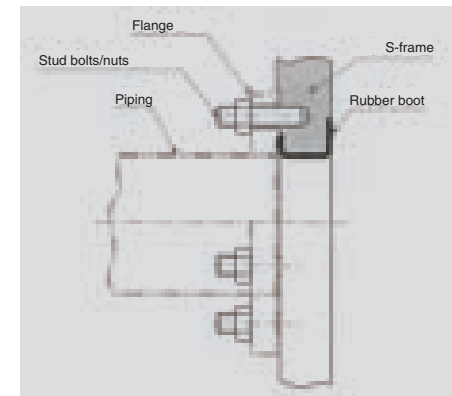

↑ For a rubber boot type, a piping gasket is not necessary.

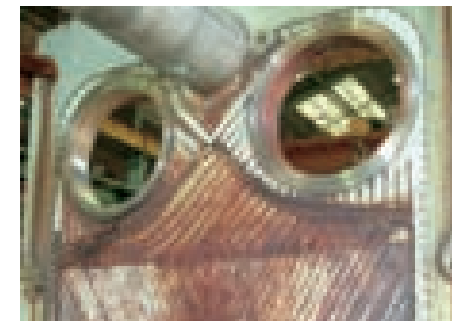

<Tightening bolts>

Tightening bolts and nuts will also begin to rust depending on the circumstance of the unit, so we recommend that periodic greasing be performed for rust prevention. Also, a bolt cover to protect the bolts, is available as an option.

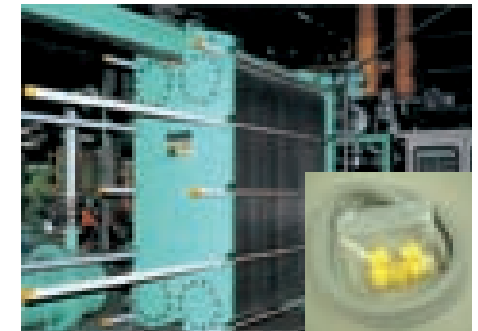

<Other spare parts>

The plates and gaskets of the plate heat exchanger can be supplied, and tightening bolts, nuts, rubber boots, and adhesive glues can be also supplied for maintenance.



↑ Maintenance parts

3— Maintenance

■ Deterioration of gaskets

Although high quality synthetic rubber is used for gaskets, deterioration due to aging is still unavoidable. Deterioration such as loss of elasticity, cracking or carbonization for rubber will decrease the sealing force, and will cause fluid leakage.

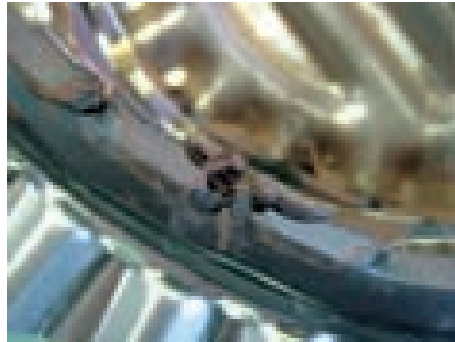

↑ Deteriorated gasket

<Gasket life time>

It is known that the following relationship exists in plate gaskets.

(1) Compression ratio ε [%] and allowable operating pressure P [MPa]

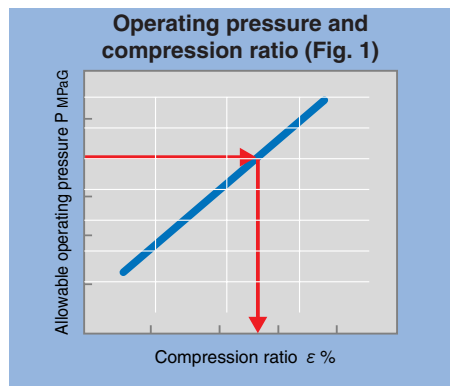

$$P = \alpha \cdot \varepsilon + \beta \dots \dots \textcircled{1}$$

Here, α and β are constants regardless of plate type, and compression ratio ε [%] can be shown by equation $\textcircled{2}$.

$$\varepsilon[\%] = \frac{(t_0 - t)}{t_0} \times 100 \dots \dots \textcircled{2}$$

t_0 : Compression free gasket thickness before operation [mm]

t : Gasket thickness when tightened [mm]

When using this relationship, it is possible to predict the minimum compression free gasket thickness t_0 [mm] that will be required at the allowable operating pressure. \dots (Fig. 1)

In addition,

(2) Permanent compression set C/S [%] and time θ [h]

$$C/S = \gamma \cdot \theta^\zeta \dots \dots \textcircled{3}$$

Here, γ and ζ are constants that are dependant on gasket material and temperature, and the permanent compression set is defined in equation $\textcircled{4}$.

$$C/S[\%] = \frac{(t_0 - t_1)}{(t_0 - t)} \times 100 \dots \dots \textcircled{4}$$

t_1 : Compression free gasket thickness after operation [mm]

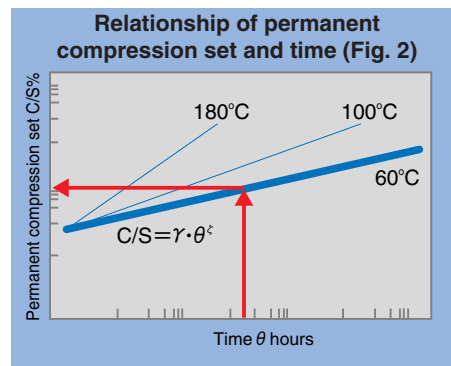

From this relationship, it will be possible to predict the gasket thickness t_1 [mm] after a certain amount of time has passed. \dots (Fig. 2)

Using this relationship, Fig. 3 shows the relationship between operating time and allowable operating pressure. When the permanent compression set of the gasket increases from operation start, and the allowable operating pressure goes down below the operating pressure, the initial leakage will occur. By retightening thereafter, the compression ratio of the gasket will be revived and it will be usable again, but when the permanent compression set increases further, the gasket will reach the limit of sealing and it will need to be replaced.

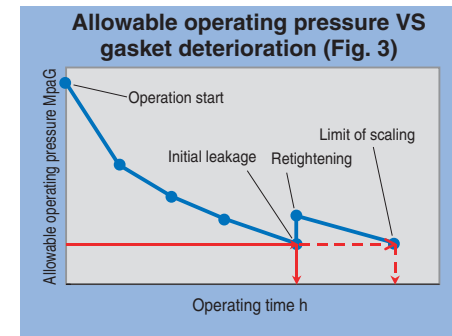

<Regasketing guideline>

Also, using the relationship of the previous section (1), it is possible to judge whether the gasket should be replaced by measuring the thickness of a gasket that has been used for a certain period of time. (Example of the judgment procedure)

<Observation>

① There were no external defects on the

gasket such as bubbling, cracking, stickiness, melting or wrinkles, and there is no leakage from the unit.

② Bending the gasket 180°, no cracks is on the gasket surface.

③ When measured gasket hardness, the result was 80°.

④ With the operating pressure of 0.5MPaG, when the gasket thickness was 3.1mm, and tightening is to be performed at the minimum gasket thickness of 2.6mm.

<Judgment>

① Visual inspection \dots passed

② Bending test \dots passed

③ Hardness \dots passed

Hardness is to be between 65° to 93°.

④ Operating pressure \dots passed

The allowable operating pressure is checked ε [%] from in equation $\textcircled{2}$ and Fig. 4.

$$\varepsilon = \frac{(3.1 - 2.6)}{3.1} \times 100 = 16.1\%$$

From Fig. 4, the allowable operating pressure 0.92 [MPa] > operating pressure 0.5 [MPa]. From ①~④ here, this gasket is possible to use.

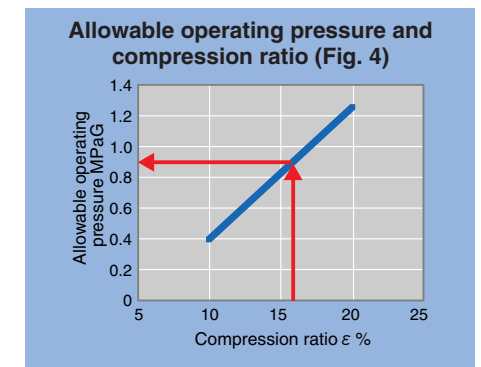

3— Maintenance

■ Cleaning methods

<Mechanical cleaning>

Remove the gasket from the plates, and clean with a deck brush, or water jet. In a case of water jet, to avoid deformation of the plate and damage to sealing surfaces, set on a flat panel and a reinforcement panel, and the water jet should be from a distance of 200mm or more.

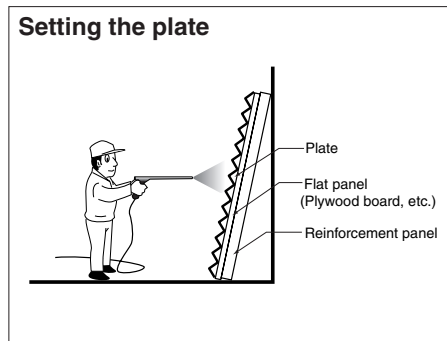

↑ Water jet



↑ Brush cleaning

Allowable water jet pressures for plate

Plate thickness mm	Plate material	Max. water jet pressure MPa
0.5	Titanium	3
0.6	Titanium	5
0.8	Titanium	10
1.0	Titanium	15
0.5	Stainless steel	5
0.6	Stainless steel	8
0.8	Stainless steel	15
1.0	Stainless steel	20

<Chemical cleaning>

Soaking... The plates are soaked in a chemical bath. In this case, it is necessary to control the process, being very careful of the chemical temperature, concentration and washing time so that the plates are not corroded by the chemicals.

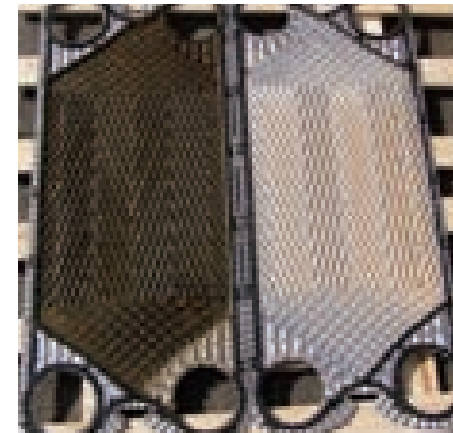

↑ Plates before cleaning



↑ Soaking in a chemical bath to remove hard scale.



↑ Plates after cleaning

Cleaning-in-place (CIP)... After washing through the heat exchanger by hot water with a higher flow rate than designed, a chemical (acid, alkali) is circulated for chemical cleaning. After chemical cleaning, rinse thoroughly with fresh water not to remain a chemical residue.



↑ Cleaning-in-place (CIP) Unit...A simple mobile CIP unit with caster wheels, and CIP cleaning for plate heat exchangers without disassembly.

4— Introduction of Maintenance Services



■ "Full Service Package"

The "Full Service Package" is a service that is provided as a full course menu for maintenance of the plate heat exchanger. The plate heat exchanger in the plant is returned as is, and we perform all maintenance work including disassembly, inspection, cleaning, regasketing assembly, and inspection. When completed, the unit is returned to the customer.



↑ Before work/after work

■ Other services

- Plate cleaning...The plate cleaning work, which is the main part of the "Full Service Package", is provided as a stand-alone service.
- Maintenance service on site...A service engineer visits to support maintenance work on site.



↑ Maintenance service on site



HISAKA
"Full Service Package"

date : _____

MFG NO. : _____

Tightening length : _____ mm

↑ After completion of "Full Service package", the certified sticker is put on the unit. Records of maintenance and replaced parts are registered in the HISAKA database, and will be utilized in future maintenance.

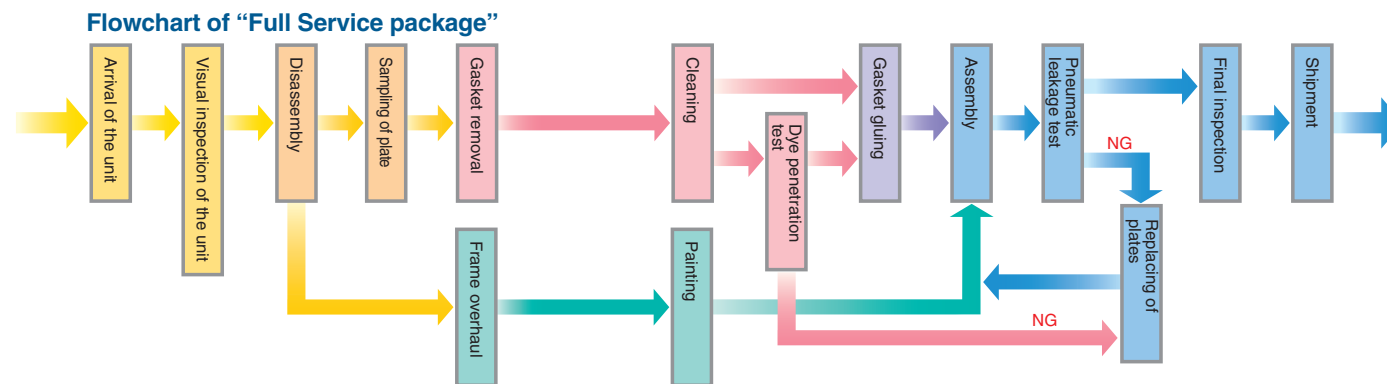

5— Fault Detection



Faults occurring in plate heat exchangers are scaling, marine growth due to usage of seawater, corrosion of plates, fatigue cracking of plates, and plate deformation. Typical examples are introduced here, along with the optimum action to correct for each case.

5-1 Scaling

There are a lot of applications for plate heat exchangers, and various types of scaling will be occurred on the plate surfaces. Here, the scaling by industrial water and scaling seawater are explained.

■ Langelier saturation index and scaling

There is water that accelerates corrosion of piping and equipment, and those that deposit calcium carbonate to form scale. To avoid the corrosion and scaling, it is necessary to have a balanced carbonate condition as in the following equation.



In methods for applying carbonate balance in water treatment, the study published by Langelier of the United States in 1936 is well known. He devised a graph for calculating the saturation pH (pHs) for water at equilibrium, and proposed the saturation index for determining corrossions or scale tendencies.

Later, other researchers added corrections to the calculations of Langelier, and this table for deriving the saturation index has been used in Japan since the latter half of the 1950's.

How to derive the saturation index (SI)

$$\text{pHs (saturation pH)} = (9.3 + \text{A} + \text{B}) - (\text{C} + \text{D})$$

- A: Evaporation residue index
- B: Temperature index
- C: Calcium hardness index
- D: Alkali level

* The index of A, B, C, and D are derived from the analysis values of the water, and the following conversion table.

$$\text{SI} = \text{pH (actual pH of the water)} - \text{pHs (saturated pH)}$$

- If SI > 0, scaling
- If SI < 0, corrosion accelerating
- If SI = 0, no corrosion, no scaling tendency

Most water in Japan is indicate SI < 0, and have corrosion accelerating tendency. To improve this tendency, "calcium hydroxide injection" and "calcium hydroxide/carbon dioxide gas injection" are well known.



Index table for A, B, C, D

Evaporation residue mg/l	A	Calcium hardness mgCaCO ₃ /l	C	Alkali level mgCaCO ₃ /l	D
50 ~ 300	0.1	10 ~ 11	0.6	10 ~ 11	1.0
400 ~ 1000	0.2	12 ~ 13	0.7	12 ~ 13	1.1
		14 ~ 17	0.8	14 ~ 17	1.2
Temperature °C	B				
0 ~ 1	2.6	18 ~ 22	0.9	18 ~ 22	1.3
2 ~ 6	2.5	23 ~ 27	1.0	23 ~ 27	1.4
7 ~ 9	2.4	28 ~ 34	1.1	28 ~ 35	1.5
10 ~ 13	2.3	35 ~ 43	1.2	36 ~ 44	1.6
14 ~ 17	2.2	44 ~ 55	1.3	45 ~ 55	1.7
18 ~ 21	2.1	56 ~ 69	1.4	56 ~ 69	1.8
22 ~ 27	2.0	70 ~ 87	1.5	70 ~ 88	1.9
28 ~ 31	1.9	88 ~ 110	1.6	89 ~ 110	2.0
32 ~ 37	1.8	111 ~ 138	1.7	111 ~ 139	2.1
38 ~ 43	1.7	139 ~ 174	1.8	140 ~ 176	2.2
44 ~ 50	1.6	175 ~ 220	1.9	177 ~ 220	2.3
51 ~ 56	1.5	230 ~ 270	2.0	230 ~ 270	2.4
57 ~ 63	1.4	280 ~ 340	2.1	280 ~ 350	2.5
64 ~ 71	1.3	350 ~ 430	2.2	360 ~ 440	2.6
72 ~ 81	1.2	440 ~ 550	2.3	450 ~ 550	2.7
		560 ~ 690	2.4	560 ~ 690	2.8
		700 ~ 870	2.5	700 ~ 880	2.9
		880 ~ 1000	2.6	890 ~ 1000	3.0

5— Faults detection

■ Marine growth

When using seawater as the cooling fluid, slime, wood chip/fiber, seaweeds and other ocean life can clog to the port holes and accumulate on the heat transfer plates, decreasing seawater flow rate and heat transfer performance.

Because of this, many plants periodically perform disassembly cleaning (generally once a year), but this is time consuming and costly. Therefore, as an anti-fouling system, HISAKA recommends using a combination with "Hot water circulation" system in which hot water is circulated for a certain amount of time, and "Air bubbling" in which compressed air is blown through the heat exchanger.



↑ **Heat exchanger Seawater inlet port hole**
Wood chips, seaweeds and shellfish are blocking the flow channel, and causing poor flow in the unit.

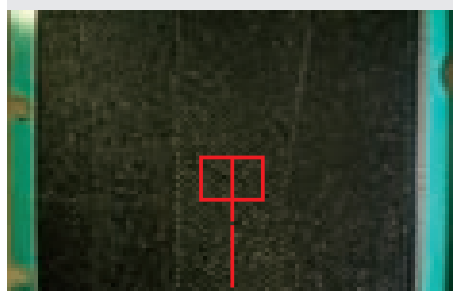

← **Plate heat transfer surface**
Slim and ocean life have accumulated, and is causing poor heat transfer.

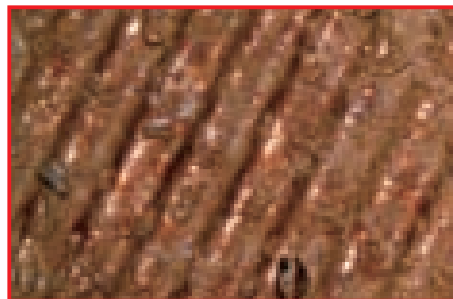

System chart of the anti-fouling system

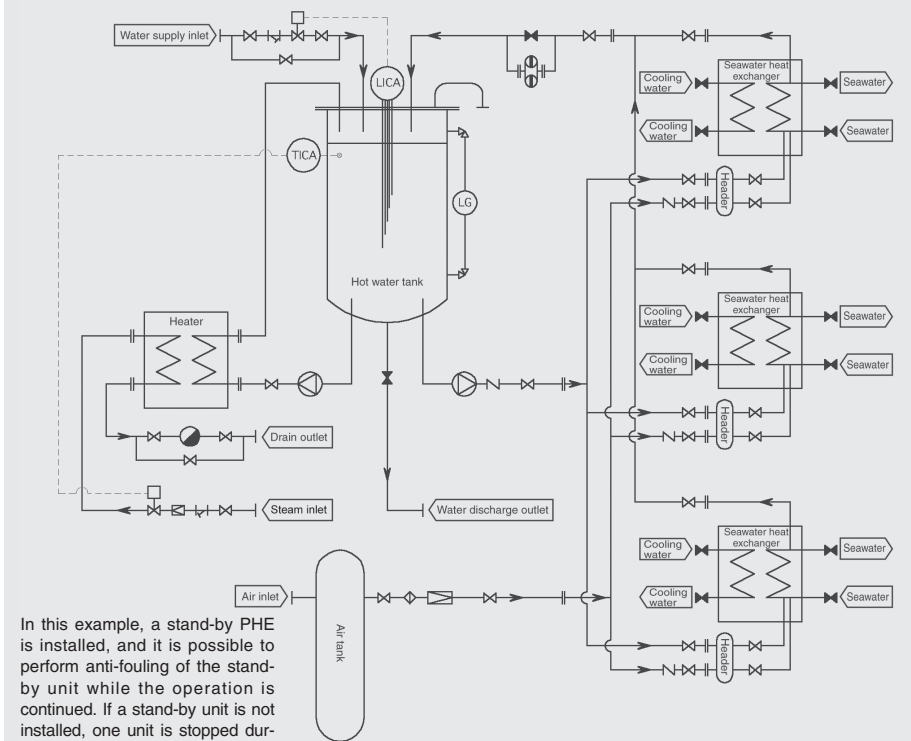

In this example, a stand-by PHE is installed, and it is possible to perform anti-fouling of the stand-by unit while the operation is continued. If a stand-by unit is not installed, one unit is stopped during plant maintenance or during low load conditions, to perform the anti-fouling operation.



↑ Commercial facility Y, K Company

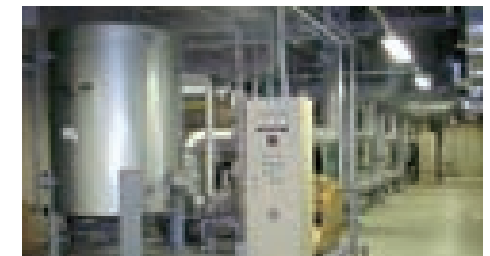

↑ Power plant I, D Company

5— Fault Detection

Seawater strainer

Objectives... Foreign objects such as seaweeds, shellfish, wood chip/fiber, etc. in seawater are removed so that they do not enter the plate heat exchanger, and prevents the clogging of the inlet port hole.

Operation principles... By switching the flow direction inside the filter (strainer) element, foreign objects are discharged from the backflushing valve.

Feature... (1) Backflushing is automatically performed with a pressure differential gauge and timer setting.

(2) The amount of water in the backflushing is 10% of normal flow, and cleaning is possible during operation.

(3) Because a cylindrical punched metal is used, the straining area is large.

(4) Maintenance of the punching metal part can be performed without disconnecting the main piping.

Backflushing of the strainer

① Normal operation period... V1 full open/V2 full closed condition

The foreign objects flowing in from the seawater inlet nozzle is removed at the strainer zone, and strained seawater flow through the seawater outlet to the heat exchanger.

② Backflushing operation period... V1 full closed/V2 full open condition

With the pressure differential gauge or timer, by closing V1 and opening V2, the seawater stream direction is forcing to change from outside of strainer zone to inside, at the time the strainer zone is backflushed and a part of seawater is discharged with foreign objects from V2.

③ Normal operation period... V1 full open/V2 full closed condition

The system will return to normal operation by the timer (backflushing time: approximately 10 seconds). At the time, the foreign objects in the inside of the strainer zone are moved to the backward of strainer.

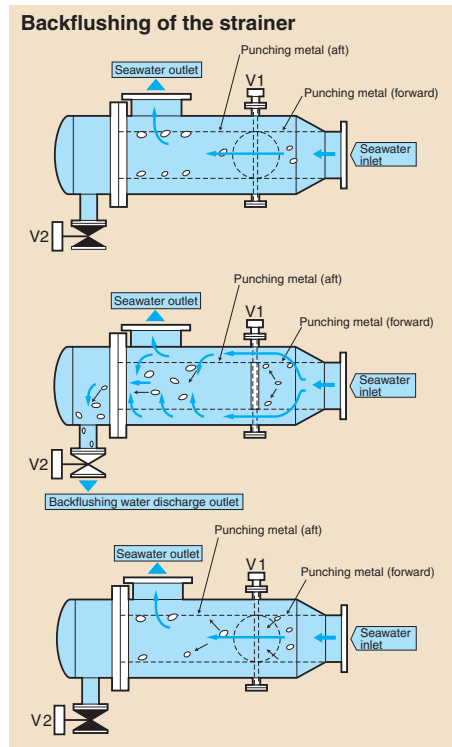

Recommendation of strainer mesh size

Model	Mesh size (mm)
EX-11	2.8 or less
EX-15	2.9 or less
UX-005	1.4 or less
UX-01	1.8 or less
UX-10	1.5 or less
UX-30	1.8 or less
UX-40	2.5 or less
UX-90	3.1 or less
UX-100,130	3.1 or less
LX-00	2.5 or less
LX-10	2.9 or less
LX-30	3.3 or less
LX-50	3.3 or less

Model	Mesh size (mm)
RX-00	1.8 or less
RX-30	2.1 or less
RX-13	1.9 or less
RX-70	2.9 or less
RX-90	2.6 or less
SX-41	1.7 or less
SX-43	1.1 or less
SX-70	1.6 or less
SX-90,90S,90M,90L	2.4 or less
WX-50	2.5 or less
WX-90	3.1 or less
FX-01	1.8 or less
FX-03	2.7 or less
FX-05	2.7 or less
YX-80A/B	1.7/2.0 or less

Inner strainer

This is an inner strainer made of punched metal with mesh diameter of 2-3mm. This is inserted in the inlet port of the plate heat exchanger, to remove foreign objects and debris in the fluid.



5— Fault Detection

5-2 Corrosion of Plate

Corrosion is a condition where the metal is chemically or electrochemically invaded due to the surrounding environment. The plates of the plate heat exchanger use anti-corrosive materials such as austenite type stainless steel and titanium, but corrosion may still occur depending on the operating conditions.

In this section, examples of past experiences in plate heat exchangers are shown, to describe action and correction on operation.

■ General corrosion

Anti corrosion metals such as stainless steel have a stable oxide film on the surface, called a passive film. In the case of stainless steel, a compound called hydroxide chrome forms a even, thin chemically stable film to maintain anti corrosion characteristics. In an general corrosion, corrosion progresses without this passive film forming, and the corrosion progresses across the entire surface evenly, so the surface loses its metallic gloss, and a rough surface is observed.

<Example>

- Operating time...Approx. 8 years
- Plate material...SUS316 (Stainless Steel 316)
- Duty...Chromium acid plating fluid/ cooling water
- Operating temperature...30°C
- Cause...Plate material is less corrosion resistance.
- Action and correction...After 8 years operation without fault, and is still possible to operate. But, it is necessary to increase the plate thickness, or change the material to titanium which is fully corrosion resistant, etc. A guideline of corrosion rate for material selection should be less than 0.1 mm/y.



↑ Magnified of the port hole of plating fluid side



↑ Port hole of plating fluid side

■ Pitting corrosion

This is a typical localized corrosion in stainless steel. Under conditions where halogen ions (mainly Cl^-) that destroy the passive film on the metal surface exist, dotted corrosion is observed. In the pit, metal ions dissolve out as atoms, and Cl^- in the fluid concentrates. Furthermore, hydrolysis of metal ions occurs, making the hydrochloric acidic condition in the pit and progresses the corrosion further.

<Example 1>

- Operating time...Approx. 1 year
- Plate material...SUS304 (Stainless Steel 304)
- Duty...Engine circulation cooling water/ cooling water
- Operating temperature...90°C
- Cause...The Cl^- ion concentration in the circulating fluid was 50ppm which is not a concentration that would be corroded, but localized concentration of Cl^- between deposit of scale and plate surface causes pitting corrosion.
- Action and correction...It is necessary to grade up the steel grade to SUS316, etc., with increased Cr, and Mo added. Also, periodic disassembly inspection and regeneration of the passive film through scale removal, and water quality control for the fluid, are recommended.



↑ Magnified of the corroded area

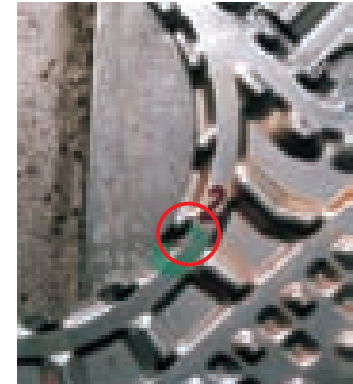

5— Fault Detection

<Example 2>

- Operating time...Approx. 5 years
- Plate material...SUS304 (Stainless Steel 304)
- Duty...Steam / city water
- Operating temperature...140°C
- Phenomenon...A tiny leak from the shoulder area of the plate on the steam side by deterioration of the gasket entered the double seal area of the plate, and with the concentration of Cl^- ions which are factors of corrosion, corrosion attacks penetrated the plate. Consequently, the city water leaked from the double seal area of plate.
- Cause...This is a pitting corrosion due to concentration of Cl^- ions, caused by leaving the tiny leakage from the steam side.
- Action and correction...Replace the gasket periodically, and change to higher grade plate material like SUS316, etc.



↑ Stress cracking (later noted) also occurred under rust deposit

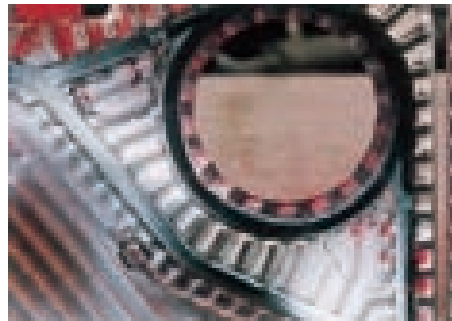

↑ Penetration cracking in red areas (the developing fluid by DPT)

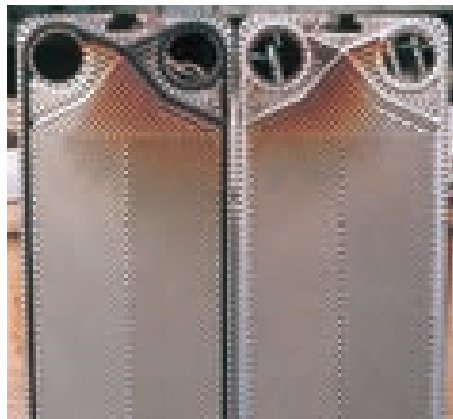

↑ Steam side



■ Crevice corrosion

This is another typical corrosion as pitting corrosion found in stainless steel, and is frequently occurring in plate heat exchangers. This is a type of corrosion occurs at gaps formed due to the structure, or narrow gaps between gasket seal surface and plate, and at gaps between sediments, and the mechanism is similar to pitting corrosion. Because the environment at gaps tend to be lacking in dissolved oxygen, the passive film is destroyed over time, and corrosion progresses.

<Example>

- Operating time...Approx. 6 months
- Plate material...Carpenter20 equivalent (High nickel Alloy)
- Duty...98% sulfuric acid / circulating cooling water
- Operating temperature...60°C
- Cause...It was found that the crevice corrosion is occurred by high concentration of Cl^- ions at the tiny gap between the cooling water side gasket and plate. Also in this case, as the crevice corrosion penetrated through the plate, 98% H_2SO_4 and cooling water were mixed and changed to the dilute sulfuric acid. Consequently, dilute acid made general corrosion collaterally.
- Action and correction...It is necessary to change the plate material to HastelloyC equivalent, and improve control to prevent concentrating the Cl^- ion concentration in the cooling water.

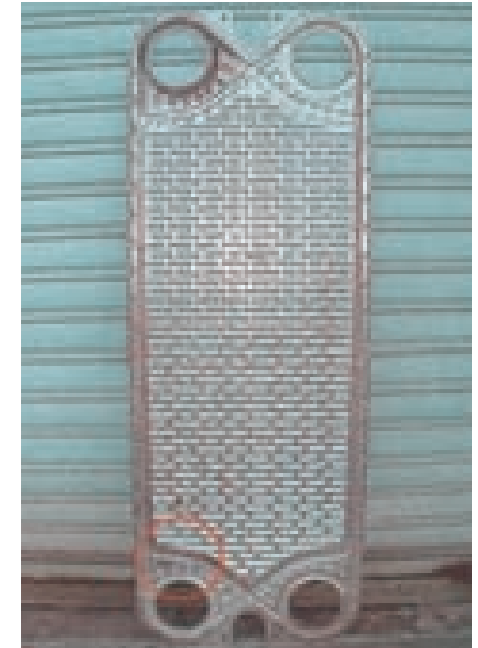

↑ Cooling water side

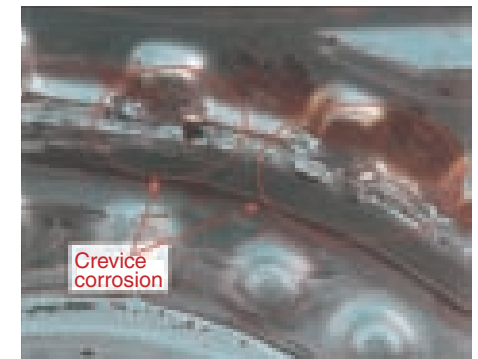

↑ Magnified of the cooling water side

Guideline curve for risk of crevice corrosion for stainless steel

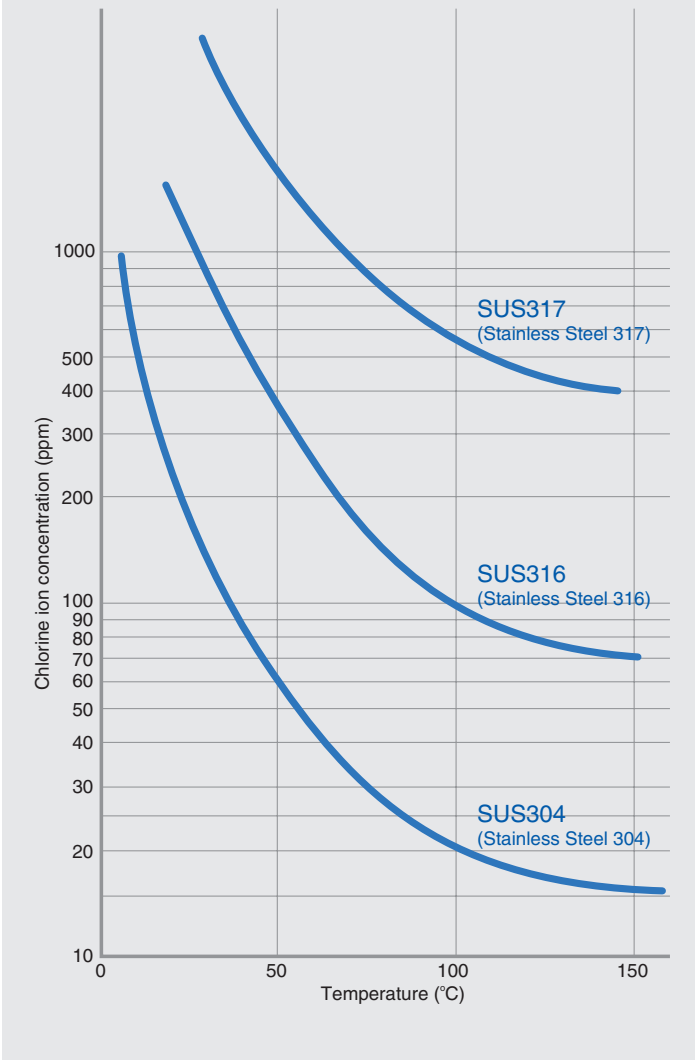

Crevice corrosion resistance of stainless steel

The main factor of crevice corrosion and pitting corrosion in austenite stainless steel, is the concentration of Cl⁻ (chlorine ions) in water. If the Cl⁻ concentration in the fluid is known, please refer to this curve to select the material.
 Example) For cooling water where the Cl⁻ ion concentration is 100ppm or less, and the maximum temperature is 40°C. There would be a slight concern for risk of corrosion with SUS304, so SUS316 is preferable.

Erosion corrosion

When the metal surface is eroded due to continuous collision of slurry, etc. in the fluid and that area becomes deeply intruded, this is called erosion corrosion. Typically this frequently occurs at narrowing or bending sections of a pipe, where the fluid velocity increases locally. Its progress depends on the type of metal or fluid, temperature, and the flow conditions of the fluid.



↑ Decreasing the plate thickness due to severe erosion corrosion

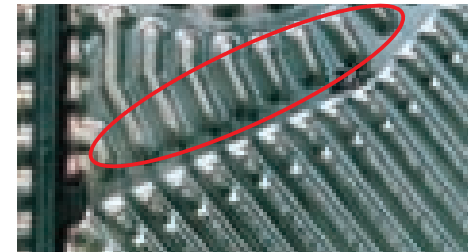

↑ Erosion corrosion at the plate contact points and near contact points

<Example>

- Operating time...Approx. 4 years
- Plate material...TP270 (Ti) (Stainless Steel 304)
- Duty...20% NaOH / industrial water
- Operating temperature...30°C
- Phenomenon...A severe general corrosion, penetrating pit and fluid leaks were found at the wet surface of 20% NaOH side.
- Cause...Deep erosion corrosion was found around the plate to plate contact points and part, and it was judged that erosion corrosion had progressed.
- Action and correction...Decreasing of the fluid velocity by increasing the number of plates, and removal of the slurry, and in addition, using the thicker plate is recommended. It is also necessary to check the corrosion resistance of the plate material.



5— Fault Detection

■ Stress corrosion cracking

In the case that tensile stress exists in the material, stress corrosion cracking is occurred from corrosion part. In the part being existing tensile stress, destruction of the passive film, movement of atoms and voids are more likely to occur, and when that area is exposed to a corrosive environment, corrosion will especially progress in this area. The corrosion will then accelerate due to the stress, and lead to cracks.

<Example 1>

- Operating time...Approx. 2 years
- Plate material...SUS304 (Stainless Steel 304)
- Duty...Primary water / secondary water
- Operating temperature...90°C
- Phenomenon...There was an occurrence of rust deposit on the back side of the gasket, and a crack occurred at the gasket seal line.
- Cause...It is possible that when chloride ions in the fluid was exposed to high temperature conditions, it was concentrated at gasket areas where the flow rate is slow, and the plate was corroded here rapidly. The crack can be determined to be stress corrosion cracking due to the rust deposit occurrence and branch shape crack.
- Action and correction...Because the plate surfaces are also corroded, using SUS304 may be corroded by this water quality. We recommend to use the material to the molybdenum added SUS316, which is anti-chloride material.



↑ Plate

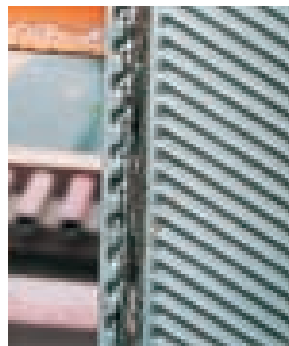

← Cracking at the gasket groove

<Example 2>

- Operating time...Approx. 3 years and 7 months
- Plate material...TP270 (Titanium 270)
- Duty...Mixed organic vapors / ethylene glycol solution
- Operating temperature...99°C
- Phenomenon...A crack occurred on the plate, and leakage was found.
- Cause...Used as a condenser for mixed organic vapors (toluene, methanol, acetone, etc.). It is supposed that a crack occurred due to the methanol in the vapors, and stress corrosion cracking occurred.
- Action and correction...Austenite type stainless steel is suited for methanol existing circumstance. We recommend changing material to the type to SUS316.



↑ Magnified of the vapor side



↑ Vapor side

5-3 Other fault detections

■ Fatigue crack

A condition where damage occurs from repeated stress on a material. Even low loads that would normally not be damaged can cause localized plastic deformation (deformation that will not return to the original form even when the external force is removed), and small cracks can progress to cause major damage.

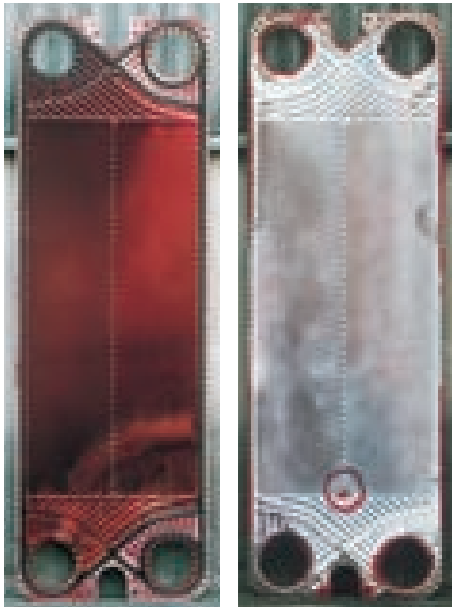

↑ Steam side (left)
Thermo oil side (right)

<Example>

- Operating time...Approx. 13 years and 8 months
- Plate material...SUS316 (Stainless Steel 316)
- Duty...Steam / thermo oil
- Operating temperature...130°C
- Phenomenon...When brine instead of steam and thermo oil was periodically used through the unit alternately, a inter-mixing of brine and thermo oil occurred. In the 5 plates, a crack was found near the end of the center of the heat transfer zone, at lower part of the plate.
- Cause...Because there are no traces of corrosion on the plates, and the position of the cracks of each plate is the same, and because this is a position where stress will concentrate and the load is high, fatigue crack is concluded to be the cause.
- Action and correction...It is concluded that fatigue crack occurred because this unit was used for long years. To increase the strength of the plates, a thicker plate is recommended.



↑ Magnified of the fatigue crack

■ Plate deformation

Main causes of plate deformation is due to excessive tightening, gasket expansion, etc., but there are also cases in which it occurs from water hammering. Water hammering occurs when water flow in a pipe is suddenly shut off, the momentum of flow makes a shock and vibrational water pressure through the pipe. In a plate heat exchanger, this occurs when pump startup and stop, valve opening/closing occurs too fast. This can cause severe problems, deforming the gasket grooves or contact points on the plate surfaces, etc.

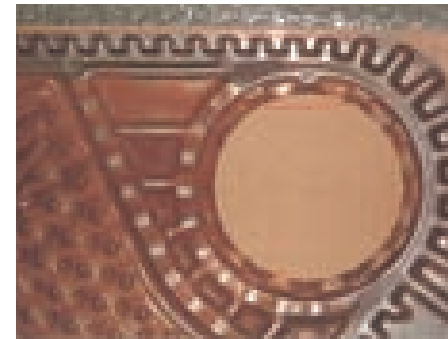

← Port hole (from the back side of the plate) can be seen to be severely deformed.

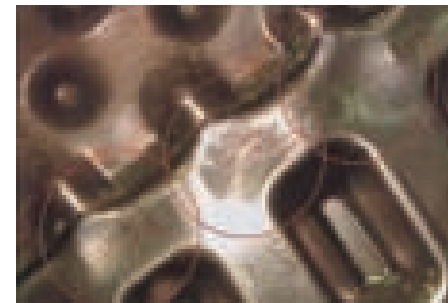

← It can be seen that the double seal area (from the back side of the plate) is hollowed.

<Example>

- Operating time...Approx. 13 years and 4 months
- Plate material...SUS316 (Stainless Steel 316)
- Duty...0.2MPaG steam / hot water
- Operating temperature...170°C
- Phenomenon...Deformation was found at the gasket groove of the plate on the hot water side.
- Cause...Because no corrosion or stress concentrations can be seen, water hammering made this damage.
- Action and correction...In this condition, the gasket cannot be compressed by plate deformation, and sealing is not possible. The plates were damaged, so all plates were replaced. It is necessary to improve the operating condition, to avoid water hammering.

6— Overhauling

In order to extend the lifetime of the plate heat exchanger, it is important to watch changes in conditions. Frequently observed faults and causes are summarized below. If those faults are detected, please contact us and inform manufacturing number of the unit.

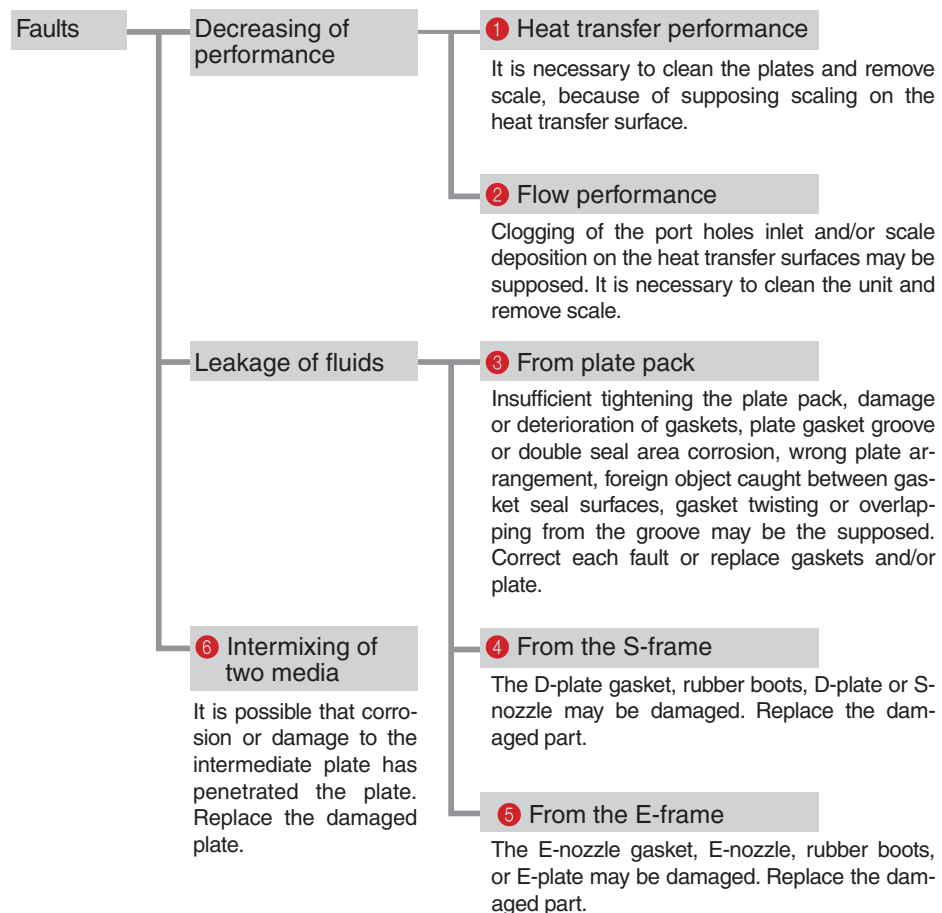

7— To Extend the Lifetime of Your Heat Exchanger

The ease of maintenance is one of the major benefits of the plate heat exchanger. It is possible to open the unit by just removing the tightening bolts, and the plates can be inspected visually. However, finding small corrosions and pinholes, and thoroughly cleaning tough scaling without damaging the thin plates require experienced skill.

As a technical supporter providing "relief" and "reliability" in maintenance service, we will work to help extend the life of the plate heat exchanger as long as possible. Please utilize our services for your maintenance.

Detailed information regarding maintenance is also available on our website's maintenance page.

<http://www.hisaka.co.jp/english/support/heatexchanger/check/index.html>

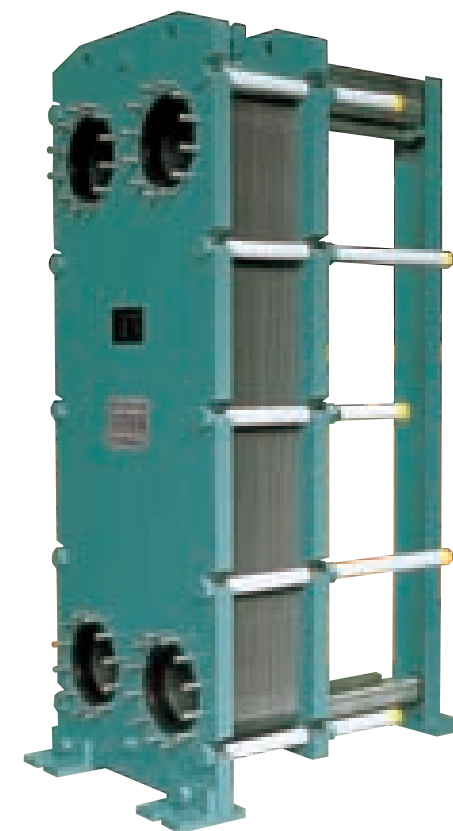



For Maintenance call.

Osaka TEL. +81-72-966-9601
Tokyo TEL. +81-3-5250-0760
Nagoya TEL. +81-52-217-2491

- ➔ Please inform the manufacturing number of the unit.
- For questions regarding content of services or products, please contact the sales department.

challenge for innovation
HISAKA WORKS, LTD. Heat Exchanger Division

Osaka : 2-1-48, Higashi-konoike-cho, Higashi-Osaka,
Osaka, 578-0973, Japan
TEL: +81-72-966-9601 FAX: +81-72-966-9602

Tokyo : KYOBASHI OM BLDG. 1-19-8, Kyobashi,
Chuo-Ku, Tokyo, 104-0031, Japan
TEL: +81-3-5250-0760 FAX: +81-3-3562-2759

Nagoya: Fujifilm Nagoya Bldg. 1-12-17, Sakae, Naka-ku,
Nagoya City, Aichi 460-0008, Japan
TEL: +81-52-217-2491 FAX: +81-52-217-2494

URL: <http://www.hisaka.co.jp/english/phe/>

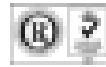

HISAKA WORKS, LTD., Heat Exchanger Division, is ISO9001 certified for its quality management system for all products including plate type heat exchangers.

HISAKA WORKS, LTD., is ISO14001 certified for its environmental management system.

No part of this brochure may be used, cited, or altered for any purpose or reproduced in any form without the prior written permission of the copyright holder.
All product details, including appearance and specifications, presented in this brochure are subject to change for improvement without prior notice.

Agent

HE-ME000302
14.06.0000.A1B